

690 Enduro R

Art. no. 3213745en



KTM

Congratulations on your decision to purchase a KTM motorcycle. You are now the owner of a state-of-the-art sports motorcycle that will give you enormous pleasure if you service and maintain it properly.

We hope you enjoy your new ride!

Enter the serial numbers of your vehicle below.

Chassis number (📖 p. 24)	Dealer's stamp
Engine number (📖 p. 25)	
Key number (📖 p. 25)	

The Owner's Manual contained the latest information for this model series at the time of going to print. However, minor differences due to further developments in design cannot be ruled out completely.

All specifications are non-binding. KTM Sportmotorcycle GmbH specifically reserves the right to modify or delete technical specifications, prices, colors, forms, materials, services, designs, equipment, etc., without prior notice and without specifying reasons, to adapt these to local conditions, as well as to stop production of a particular model without prior notice. KTM accepts no liability for delivery options, deviations from figures and descriptions, misprints, and other errors. The models portrayed partly contain special equipment that does not belong to the regular scope of supply.

© 2017 KTM Sportmotorcycle GmbH, Mattighofen Austria
All rights reserved



3213745en

08/2017

DEAR KTM CUSTOMER

Reproduction, even in part, as well as copying of all kinds, is permitted only with the express written permission of the copyright owner.



REG.NO. 12 100 6061

KTM Sportmotorcycle GmbH
Stallhofnerstraße 3
5230 Mattighofen, Austria

ISO 9001(12 100 6061)

According to the international quality management standard ISO 9001, KTM uses quality assurance processes that lead to the maximum possible quality of the products.

Issued by: TÜV Management Service

This document is valid for the following models:

690 Enduro R EU (F9703R8)

1	MEANS OF REPRESENTATION	9	4	VIEW OF VEHICLE	20
	1.1 Symbols used	9	4.1	View of vehicle, front left (example) ...	20
	1.2 Formats used.....	10	4.2	View of vehicle, rear right (example).....	22
2	SAFETY ADVICE.....	11	5	SERIAL NUMBERS	24
	2.1 Use definition – intended use.....	11	5.1	Chassis number	24
	2.2 Misuse.....	11	5.2	Type label	24
	2.3 Safety advice.....	11	5.3	Key number.....	25
	2.4 Degrees of risk and symbols	12	5.4	Engine number	25
	2.5 Tampering warning.....	13	5.5	Fork part number	26
	2.6 Safe operation	13	5.6	Shock absorber article number	26
	2.7 Protective clothing	14	6	CONTROLS.....	27
	2.8 Work rules.....	15	6.1	Clutch lever.....	27
	2.9 Environment.....	15	6.2	Hand brake lever.....	27
	2.10 Owner's Manual	16	6.3	Throttle grip	28
3	IMPORTANT NOTES.....	17	6.4	Horn button.....	28
	3.1 Manufacturer and implied warranty....	17	6.5	Light switch	29
	3.2 Operating and auxiliary substances	17	6.6	Turn signal switch.....	29
	3.3 Spare parts, accessories	17	6.7	Emergency OFF switch	30
	3.4 Service	18	6.8	Electric starter button.....	31
	3.5 Figures	18	6.9	Ignition/steering lock.....	31
	3.6 Customer service.....	18			

TABLE OF CONTENTS

6.10	Combination instrument	32	7	PREPARING FOR USE.....	50
6.10.1	Combination instrument overview.....	32	7.1	Advice on preparing for first use	50
6.10.2	Function buttons	33	7.2	Running in the engine	52
6.10.3	Tachometer	33	7.3	Loading the vehicle	53
6.10.4	Indicator lamps	34	8	RIDING INSTRUCTIONS.....	56
6.10.5	Display	35	8.1	Checks and maintenance measures when preparing for use	56
6.10.6	Speed display.....	36	8.2	Starting the vehicle.....	57
6.10.7	Setting the kilometers or miles.....	37	8.3	Starting off.....	60
6.10.8	Time.....	38	8.4	Shifting, riding	60
6.10.9	Setting the clock	38	8.5	Applying the brakes.....	66
6.10.10	ODO display	39	8.6	Stopping, parking.....	68
6.10.11	Setting/resetting display TRIP 1	39	8.7	Transport	70
6.10.12	Setting/resetting display TRIP 2	40	8.8	Refueling	71
6.10.13	TRIP F display	41	9	SERVICE SCHEDULE	74
6.10.14	GEAR display	42	9.1	Additional information	74
6.10.15	Coolant temperature indicator	42	9.2	Required work	74
6.11	Opening the filler cap.....	43	9.3	Recommended work	77
6.12	Closing filler cap.....	45	10	TUNING THE CHASSIS	78
6.13	Seat unlocking.....	45	10.1	Fork/shock absorber	78
6.14	Handrails	46	10.2	Adjusting the compression damping of the fork	78
6.15	Passenger footrest.....	46			
6.16	Shift lever	47			
6.17	Foot brake lever	48			
6.18	Side stand.....	48			







10.3	Adjusting the rebound damping of the fork.....	80	11	SERVICE WORK ON THE CHASSIS.....	95
10.4	Compression damping of the shock absorber.....	81	11.1	Raising the motorcycle with a lift stand.....	95
10.5	Adjusting the low-speed compression damping of the shock absorber.....	81	11.2	Removing the motorcycle from the lift stand.....	95
10.6	Adjusting the high-speed compression damping of the shock absorber.....	83	11.3	Cleaning the dust boots of the fork legs.....	96
10.7	Adjusting the rebound damping of the shock absorber.....	84	11.4	Loosening the fork protection.....	98
10.8	Measuring the unloaded rear wheel sag.....	85	11.5	Positioning the fork protector.....	98
10.9	Checking the static sag of the shock absorber.....	87	11.6	Checking the play of the steering head bearing.....	99
10.10	Checking the riding sag of the shock absorber.....	88	11.7	Adjusting the play of the steering head bearing 	101
10.11	Adjusting the spring preload of the shock absorber 	89	11.8	Removing the seat.....	102
10.12	Adjusting the riding sag 	91	11.9	Mounting the seat.....	102
10.13	Handlebar position.....	92	11.10	Removing the air filter 	103
10.14	Adjusting handlebar position 	93	11.11	Installing the air filter 	104
			11.12	Checking the chain for dirt.....	105
			11.13	Cleaning the chain.....	106
			11.14	Checking the chain tension.....	107
			11.15	Adjusting the chain tension.....	109
			11.16	Checking the chain, rear sprocket, engine sprocket, and chain guide....	111
			11.17	Adjusting chain guide 	116

TABLE OF CONTENTS

11.18	Adjusting the basic position of the clutch lever	117	12.13	Changing the rear brake linings 🛠️.....	143
11.19	Checking/correcting the fluid level of the hydraulic clutch.....	118	13	WHEELS, TIRES	148
11.20	Removing the engine guard.....	120	13.1	Removing the front wheel 🛠️.....	148
11.21	Installing the engine guard	121	13.2	Installing the front wheel 🛠️	150
12	BRAKE SYSTEM	122	13.3	Removing the rear wheel 🛠️.....	152
12.1	Antilock brake system (ABS)	122	13.4	Installing the rear wheel 🛠️.....	154
12.2	Adjusting the basic position of the hand brake lever	124	13.5	Checking the rear hub rubber dampers 🛠️.....	156
12.3	Checking the brake discs	125	13.6	Checking the tire condition	158
12.4	Checking brake fluid level of front brake	126	13.7	Checking the tire air pressure.....	160
12.5	Topping up brake fluid of front brake. 🛠️	127	13.8	Checking the spoke tension.....	162
12.6	Checking the front brake linings	130	14	ELECTRICAL SYSTEM	164
12.7	Changing the front brake linings 🛠️.....	131	14.1	Removing the battery 🛠️.....	164
12.8	Checking the free travel of foot brake lever	136	14.2	Installing the battery 🛠️.....	167
12.9	Adjusting the basic position of the foot brake lever 🛠️.....	137	14.3	Recharging the battery 🛠️.....	169
12.10	Checking rear brake fluid level	139	14.4	Changing the main fuse	172
12.11	Adding rear brake fluid 🛠️	140	14.5	Changing the ABS fuses	174
12.12	Checking the rear brake linings	142	14.6	Changing the fuses of individual power consumers	176
			14.7	Removing the headlight mask with the headlight	179
			14.8	Installing the headlight mask with the headlight	180
			14.9	Changing the headlight bulb	181

14.10	Changing the parking light bulb.....	183	17.2	Changing the engine oil and filter, cleaning the oil screens 🛠️.....	208
14.11	Changing the turn signal bulb	184	17.3	Draining the engine oil 🛠️.....	208
14.12	Checking the headlight setting	186	17.4	Removing the oil filter 🛠️.....	210
14.13	Adjusting the headlight range.....	187	17.5	Cleaning the oil screens 🛠️.....	211
14.14	Diagnostics connector	188	17.6	Installing the oil filter 🛠️.....	214
15	COOLING SYSTEM	189	17.7	Filling up with engine oil 🛠️.....	214
15.1	Cooling system	189	17.8	Adding engine oil.....	216
15.2	Checking the antifreeze and coolant level.....	190	18	CLEANING, CARE	218
15.3	Checking the coolant level	193	18.1	Cleaning the motorcycle	218
15.4	Draining the coolant 🛠️.....	195	18.2	Checks and maintenance steps for winter operation.....	221
15.5	Filling/bleeding the cooling system 🛠️.....	197	19	STORAGE.....	223
15.6	Changing the coolant 🛠️.....	199	19.1	Storage	223
16	TUNING THE ENGINE.....	203	19.2	Preparing for use after storage.....	225
16.1	Adjusting the engine characteristic.....	203	20	TROUBLESHOOTING	226
16.2	Checking the basic position of the shift lever.....	204	21	BLINK CODE	230
16.3	Adjusting the basic position of the shift lever 🛠️.....	205	22	TECHNICAL DATA.....	237
17	SERVICE WORK ON THE ENGINE	207	22.1	Engine	237
17.1	Checking the engine oil level.....	207	22.2	Engine tightening torques	239
			22.3	Capacities	244
			22.3.1	Engine oil	244

TABLE OF CONTENTS

22.3.2	Coolant	244
22.3.3	Fuel	244
22.4	Chassis	244
22.5	Electrical system.....	246
22.6	Tires	247
22.7	Fork.....	248
22.8	Shock absorber	249
22.9	Chassis tightening torques	250
23	SUBSTANCES	257
24	AUXILIARY SUBSTANCES	261
25	STANDARDS	263
26	INDEX OF SPECIAL TERMS	264
27	LIST OF ABBREVIATIONS.....	265
28	LIST OF SYMBOLS.....	266
28.1	Red symbols.....	266
28.2	Yellow and orange symbols.....	266
28.3	Green and blue symbols.....	267
INDEX	268

1.1 Symbols used

The meaning of specific symbols is described below.



Indicates an expected reaction (e.g. of a work step or a function).



Indicates an unexpected reaction (e.g. of a work step or a function).



All work marked with this symbol requires specialist knowledge and technical understanding. In the interest of your own safety, have these jobs performed by an authorized KTM workshop! Your motorcycle will be optimally cared for there by specially trained experts using the auxiliary tools required.



Indicates a page reference (more information is provided on the specified page).



Indicates information with more details or tips.



Indicates the result of a testing step.

1 MEANS OF REPRESENTATION

V

Indicates a voltage measurement.

A

Indicates a current measurement.



Indicates the end of an activity, including potential rework.

1.2 Formats used

The typographical formats used in this document are explained below.

Proprietary name

Indicates a proprietary name.

Name®

Indicates a protected name.

Brand™

Indicates a brand available on the open market.

Underlined terms

Refer to technical details of the vehicle or indicate technical terms, which are explained in the glossary.

2.1 Use definition – intended use

The vehicle is designed and constructed to withstand the usual demands of regular traffic and use on gentle terrain (unpaved roads). This vehicle is not suitable for use on race tracks.



Info

This vehicle is only authorized for operation on public roads in its homologated version.

2.2 Misuse

The vehicle must only be used as intended.

Dangers can arise for people, property and the environment through use not as intended.

Any use of the vehicle beyond the intended and defined use constitutes misuse.

Misuse also includes the use of operating and auxiliary fluids which do not meet the required specification for the respective use.

2.3 Safety advice

A number of safety instructions need to be followed to operate the model described safely. Therefore read this instruction and all further instructions included carefully. The safety instructions are highlighted in the text and are referred to at the relevant passages.

2 SAFETY ADVICE



Info

Various information and warning labels are attached in prominent locations on the model described. Do not remove any information or warning labels. If they are missing, you or others may not recognize dangers and may therefore be injured.

2.4 Degrees of risk and symbols



Danger

Indicates a danger that will immediately and invariably lead to fatal or serious permanent injury if the appropriate measures are not taken.



Warning

Indicates a danger that is likely to lead to fatal or serious injury if the appropriate measures are not taken.



Caution

Indicates a danger that may lead to minor injuries if the appropriate measures are not taken.

Note

Indicates a danger that will lead to considerable machine and material damage if the appropriate measures are not taken.



Warning

Indicates a danger that will lead to environmental damage if the appropriate measures are not taken.

2.5 Tampering warning

Tampering with the noise control system is prohibited. Federal law prohibits the following acts or the causing thereof:

- 1 The removal or rendering inoperative by any person other than for purposes of maintenance, repair, or replacement, of any device or element of design incorporated into any new vehicle for the purpose of noise control prior to its sale or delivery to the ultimate purchaser or while it is in use, or
- 2 the use of the vehicle after such device or element of design has been removed or rendered inoperative by any person.

Among those acts presumed to constitute tampering are the acts listed below:

- 1 Removal or puncturing of the main silencer, baffles, header pipes or any other components which conduct exhaust gases.
- 2 Removal or puncturing of parts of the intake system.
- 3 Lack of proper maintenance.
- 4 Replacing moving part of the vehicle, or parts of the exhaust or intake system, with parts other than those specified by the manufacturer.

2.6 Safe operation



Danger

Danger of accidents A rider who is not fit to ride poses a danger to him or herself and others.

- Do not operate the vehicle if you are not fit to ride due to alcohol, drugs or medication.
- Do not operate the vehicle if you are physically or mentally impaired.

2 SAFETY ADVICE



Danger

Danger of poisoning Exhaust gases are toxic and inhaling them may result in unconsciousness and death.

- Always make sure there is sufficient ventilation when running the engine.
- Use an effective exhaust extraction system when starting or running the engine in an enclosed space.



Warning

Danger of burns Some vehicle components become very hot when the vehicle is operated.

- Do not touch any parts such as the exhaust system, radiator, engine, shock absorber, or brake system before the vehicle parts have cooled down.
- Let the vehicle parts cool down before you perform any work on the vehicle.

Only operate the vehicle when it is in perfect technical condition, in accordance with its intended use, and in a safe and environmentally compatible manner.

An appropriate driver's license is needed to ride the vehicle on public roads.

Have malfunctions that impair safety promptly eliminated by an authorized KTM workshop.

Adhere to the information and warning labels on the vehicle.

2.7 Protective clothing



Warning

Risk of injury Missing or poor protective clothing presents an increased safety risk.

- Wear appropriate protective clothing such as helmet, boots, gloves as well as trousers and a jacket with protectors on all rides.
 - Always wear protective clothing that is in good condition and meets the legal regulations.
-

In the interest of your own safety, KTM recommends that you only operate the vehicle while wearing protective clothing.

2.8 Work rules

Special tools are necessary for certain tasks. The tools are not a component of the vehicle, but can be ordered using the number in parentheses. Example: bearing puller (15112017000)

During assembly, use new parts to replace parts which cannot be reused (e.g. self-locking screws and nuts, seals, sealing rings, O-rings, pins, and lock washers).

In the case of certain screws, a thread locker (e.g. **Loctite**[®]) is required. Apply according to the manufacturer's instructions.

After disassembly, clean the parts that are to be reused and check them for damage and wear. Change damaged or worn parts.

After completing a repair or service work, check the operating safety of the vehicle.

2.9 Environment

If you use your motorcycle responsibly, you can ensure that problems and conflicts do not occur. To protect the future of the motorcycle sport, make sure that you use your motorcycle legally, display environmental consciousness, and respect the rights of others.

When disposing of used oil, other operating and auxiliary fluids, and used components, comply with the laws and regulations of the respective country.

Because motorcycles are not subject to the EU regulations governing the disposal of used vehicles, there are no legal regulations that pertain to the disposal of an end-of-life motorcycle. Your authorized KTM dealer will be glad to advise you.

2.10 Owner's Manual

It is important that you read this Owner's Manual carefully and completely before making your first trip. The Owner's Manual contains useful information and many tips on how to operate, handle, and maintain your motorcycle. Only then will you find out how to customize the vehicle ideally for your own use and how you can protect yourself from injury.

Keep the Owner's Manual in an accessible place to enable you to refer to it as needed.

If you would like to know more about the vehicle or have questions on the material you read, please contact an authorized KTM dealer.

The Owner's Manual is an important component of the vehicle and must be handed over to the new owner if the vehicle is sold.

The Owner's Manual is also available for download from your authorized KTM dealer and on the KTM website.
International KTM Website: <http://www.ktm.com>

3.1 Manufacturer and implied warranty

The work specified in the service schedule may only be performed in an authorized KTM workshop and must be recorded in both the Service & Warranty Booklet and in **KTM Dealer.net**, otherwise any warranty coverage will become void. Damage or secondary damage caused by tampering with and/or conversions on the vehicle are not covered by the warranty.

Additional information on the manufacturer or implied warranty and the procedures involved can be found in the Service & Warranty Booklet.

3.2 Operating and auxiliary substances



Warning

Environmental hazard Improper handling of fuel is a danger to the environment.

- Do not allow fuel to enter the groundwater, the soil, or the sewage system.

Use operating and auxiliary substances (such as fuel and lubricants) as specified in the Owner's Manual.

3.3 Spare parts, accessories

For your own safety, only use spare parts and accessory products that are approved and/or recommended by KTM and have them installed by an authorized KTM workshop. KTM accepts no liability for other products and any resulting damage or loss.

Certain spare parts and accessory products are specified in parentheses in the descriptions. Your authorized KTM dealer will be glad to advise you.

3 IMPORTANT NOTES

The current **KTM PowerParts** for your vehicle can be found on the KTM website.
International KTM Website: <http://www.ktm.com>

3.4 Service

A prerequisite for perfect operation and prevention of premature wear is that the service, care, and tuning work on the engine and chassis is properly carried out as described in the Owner's Manual. Incorrect adjustment and tuning of the engine and chassis can lead to damage and breakage of components.

Use of the vehicle under difficult conditions, such in rain, high heat or with a heavy load, can lead to considerably more rapid wear of components such as the drive train, brake system, or suspension components. For this reason, it may be necessary to inspect or replace parts before the next scheduled service.

It is imperative that you adhere to the stipulated run-in times and service intervals. If you observe these exactly, you will ensure a much longer service life for your motorcycle.

3.5 Figures

The figures contained in the manual may depict special equipment.

In the interest of clarity, some components may be shown disassembled or may not be shown at all. It is not always necessary to disassemble the component to perform the activity in question. Please follow the instructions in the text.

3.6 Customer service

Your authorized KTM dealer will be happy to answer any questions you may have on your vehicle and KTM.

A list of authorized KTM dealers can be found on the KTM website.
International KTM Website: <http://www.ktm.com>

4 VIEW OF VEHICLE

4.1 View of vehicle, front left (example)



- ① Hand brake lever (📖 p. 27)
- ② Clutch lever (📖 p. 27)
- ③ Handrails (📖 p. 46)
- ④ Filler cap
- ⑤ Passenger footrest (📖 p. 46)
- ⑥ Seat unlocking (📖 p. 45)
- ⑦ Side stand (📖 p. 48)
- ⑧ Shift lever (📖 p. 47)
- ⑨ Engine number (📖 p. 25)

4 VIEW OF VEHICLE

4.2 View of vehicle, rear right (example)

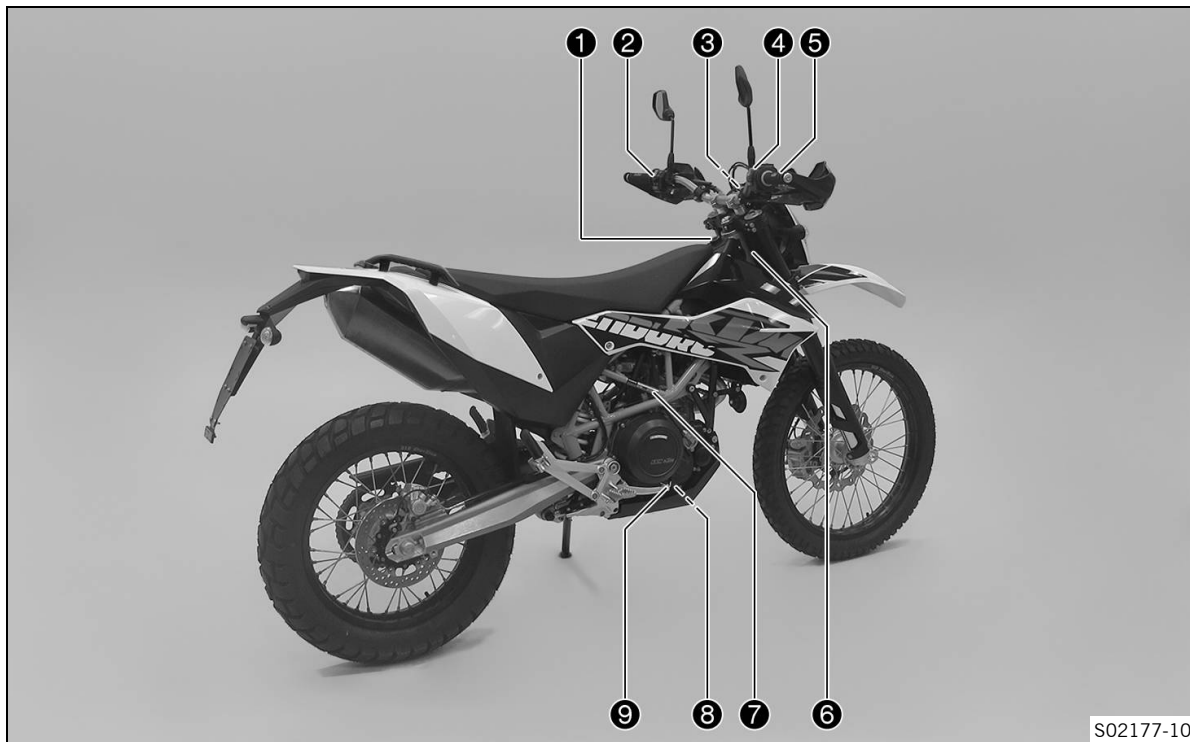

- ① Ignition/steering lock (📖 p. 31)
- ② Light switch (📖 p. 29)
- ② Turn signal switch (📖 p. 29)
- ② Horn button (📖 p. 28)
- ③ Function buttons (📖 p. 33)
- ③ Indicator lamps (📖 p. 34)
- ④ Emergency OFF switch (📖 p. 30)
- ④ Electric starter button (📖 p. 31)
- ⑤ Throttle grip (📖 p. 28)
- ⑥ Chassis number (📖 p. 24)
- ⑦ Type label (📖 p. 24)
- ⑧ Engine oil level viewer
- ⑨ Foot brake lever (📖 p. 48)

5 SERIAL NUMBERS

5.1 Chassis number

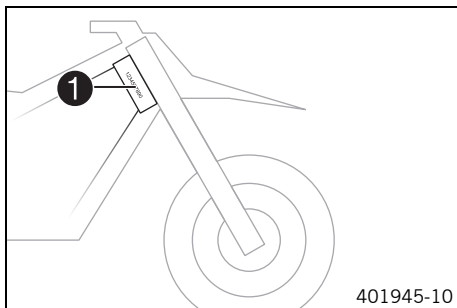

The chassis number **1** is stamped on the steering head on the right.

5.2 Type label

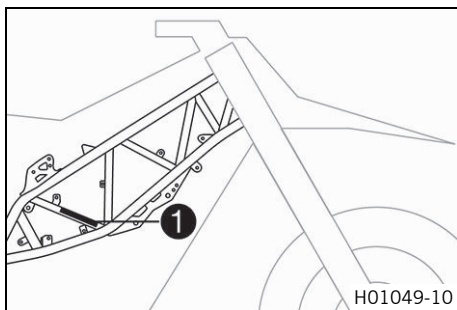

The type label **1** is located on the right side of the frame.

5.3 Key number

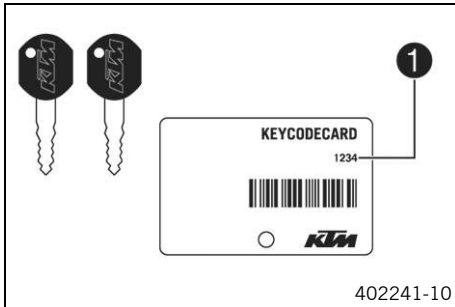

The key number **1** can be found on the **KEYCODECARD**.



Info

You need the key number to order a spare key. Keep the **KEYCODECARD** in a safe place.

5.4 Engine number

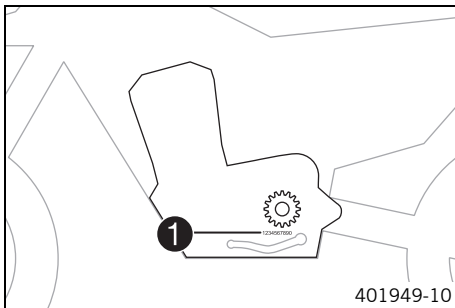

The engine number **1** is stamped on the left side of the engine under the engine sprocket.

5 SERIAL NUMBERS

5.5 Fork part number

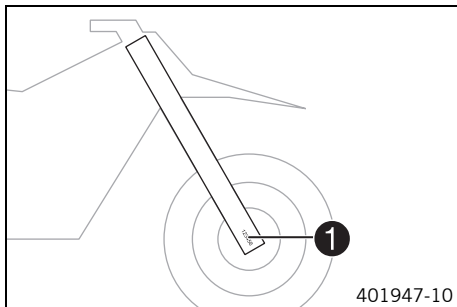

The fork part number **1** is stamped on the inner side of the fork stub.

5.6 Shock absorber article number

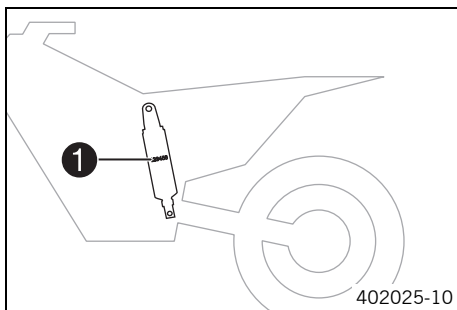

The shock absorber article number **1** is on the left side of the shock absorber.

6.1 Clutch lever

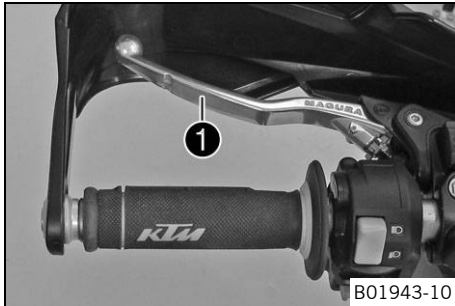

The clutch lever ① is fitted on the left side of the handlebar. The clutch is hydraulically operated and self-adjusting.

6.2 Hand brake lever

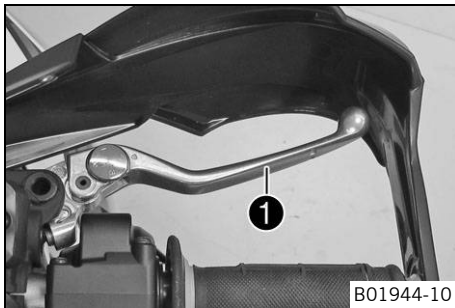

The hand brake lever ① is fitted on the right side of the handlebar. The hand brake lever operates the front brake.

6 CONTROLS

6.3 Throttle grip

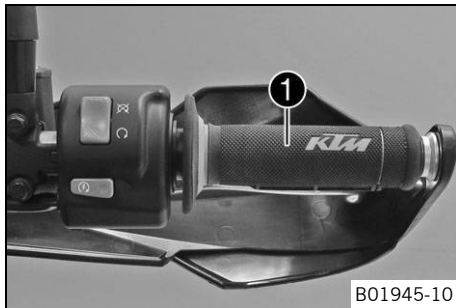



The throttle grip **1** is fitted on the right side of the handlebar.

6.4 Horn button



The horn button **1** is fitted on the left side of the handlebar.

Possible states



- Horn button  in neutral position
- Horn button  pressed – The horn is operated in this position.

6.5 Light switch



The light switch ① is fitted on the left side of the handlebar.

Possible states



	Low beam on – Light switch is turned downward. In this position, the low beam and tail light are switched on.
	High beam on – Light switch is turned upward. In this position, the high beam and tail light are switched on.

6.6 Turn signal switch



The turn signal switch ① is fitted on the left side of the handlebar.

Possible states

	Turn signal off
	Turn signal light, left, on – Turn signal switch pressed to the left. The turn signal switch returns automatically to the central position after use.
	Turn signal light, right, on – Turn signal switch pressed to the right. The turn signal switch returns automatically to the central position after use.



To switch off the turn signal light, press the turn signal switch towards the switch case.

6.7 Emergency OFF switch



The emergency OFF switch ① is fitted on the right side of the handlebar.

Possible states

	Emergency OFF switch off – In this position, the ignition circuit is interrupted, a running engine stops, and the engine cannot be started.
	Emergency OFF switch on – This position is necessary for operation as the ignition circuit is closed.

6.8 Electric starter button



The electric starter button **1** is fitted on the right side of the handlebar.

Possible states

- Electric starter button **1** in basic position
- Electric starter button **1** pressed – In this position, the electric starter is actuated.

6.9 Ignition/steering lock

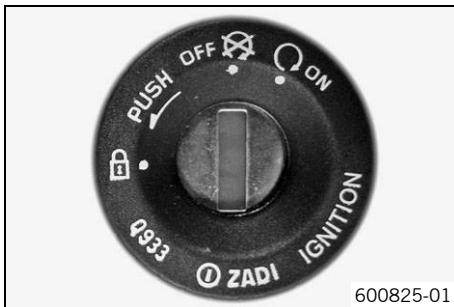

The ignition/steering lock **1** is located in front of the seat.

Possible states

	<p>Ignition OFF – In this position, the ignition circuit is interrupted, a running engine stops, and a non-running engine will not start. The ignition key can be removed.</p>
	<p>Ignition ON – In this position, the ignition circuit is closed and the engine can be started.</p>



Steering locked – In this position, the ignition circuit is interrupted and the steering locked. The ignition key can be removed.

6.10 Combination instrument

6.10.1 Combination instrument overview

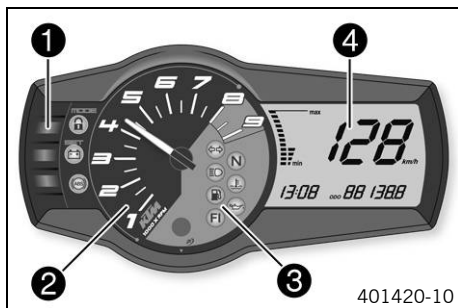

The combination instrument is attached in front of the handlebar. The combination instrument is divided into 4 function areas.

- 1 Function buttons (📖 p. 33)
- 2 Tachometer (📖 p. 33)
- 3 indicator lamps (📖 p. 34)
- 4 Display (📖 p. 35)

6.10.2 Function buttons

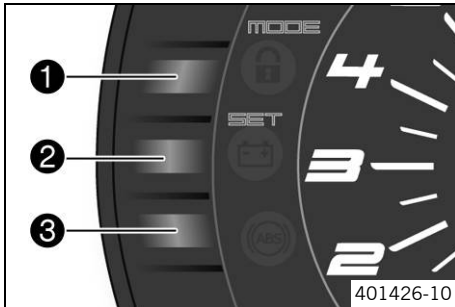

You can change the display mode with the **MODE** button ①. Possible display modes are distance traveled (**ODO**), trip master 1 (**TRIP 1**) and trip master 2 (**TRIP 2**). Press the **SET** button ② to reset the trip master 1 function (**TRIP 1**) and trip master 2 function (**TRIP 2**) to **0.0**. The ABS can be switched off using button ③.

6.10.3 Tachometer

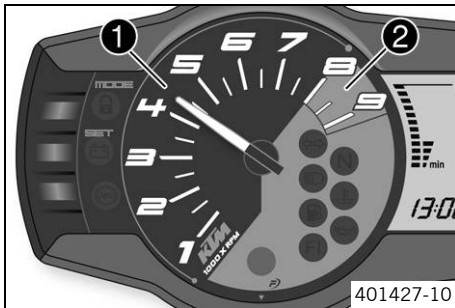





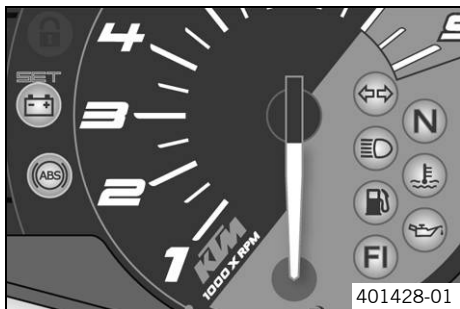

The tachometer ① shows the engine speed in revolutions per minute. The red marking ② shows the excess speed range of the engine.



6.10.4 Indicator lamps



The indicator lamps offer additional information about the operating state of the motorcycle.

Possible states

	Turn signal indicator lamp flashes green – The turn signal is switched on.
	The idle indicator lamp lights up green – The transmission is in idle.
	The high beam indicator lamp lights up blue – The high beam is switched on.
	The coolant temperature warning lamp lights up red – The coolant temperature has reached a critical value.
	The fuel level warning lamp lights up yellow – The fuel level has reached the reserve mark. The display switches to TRIP F .
	The oil pressure warning lamp lights up red – Engine oil pressure is too low. Stop immediately, taking care not to endanger yourself or other road users in the process, and switch off the engine.

	<p>Malfunction indicator lamp lights up/flashes yellow – The <u>OBD</u> has detected an error in the vehicle electronics. Come safely to a halt, and contact an authorized KTM workshop.</p>
	<p>The battery warning lamp lights up red – The voltage in the vehicle system is too low.</p>
	<p>ABS warning lamp lights up/flashes yellow – Status or error messages relating to <u>ABS</u>.</p>

6.10.5 Display

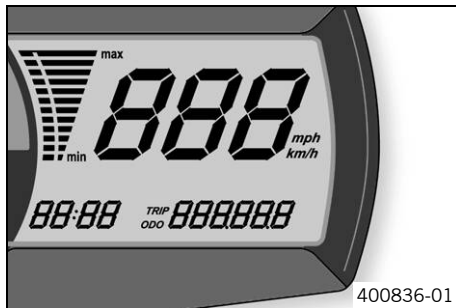

When the ignition is switched on, all display segments light up for one second as a function check.

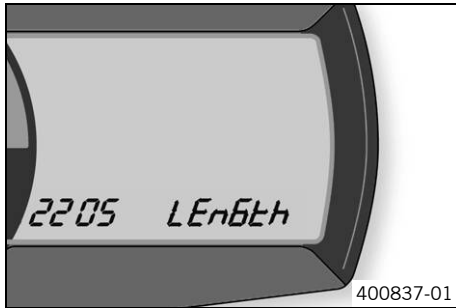

LEnGth

After the display function check, the wheel circumference **LEnGth** is displayed for one second.



Info

2205 mm equals the circumference of the 21" front wheel with a series production tire.

The display then changes to the last selected mode.

6.10.6 Speed display



The speed **1** is shown in kilometers per hour **km/h** or in miles per hour **mph**.

6.10.7 Setting the kilometers or miles



Info

If the unit is changed, the value is retained and converted accordingly.
Make the setting according to the country.

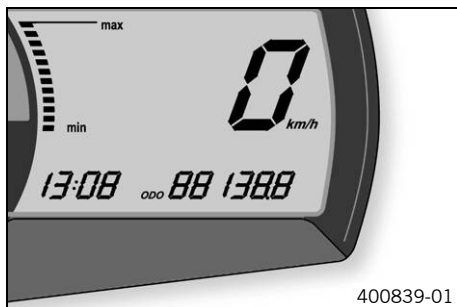

Condition

The motorcycle is stationary.

- Switch on the ignition by turning the ignition key to position **ON** .
- Press the **MODE** button repeatedly until the **ODO** display mode is active.
- Keep the **MODE** button pressed until the display mode changes from **km/h** to **mph** or from **mph** to **km/h**.

Guideline

Activation duration of MODE button	10 s
---	------



6.10.8 Time



The time is shown in area ❶ of the display.



Info

The time must be reset after the battery was disconnected or the fuse was removed.

6.10.9 Setting the clock

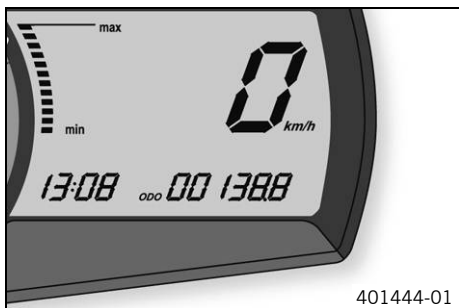

Condition

The motorcycle is stationary.

- Switch on the ignition by turning the ignition key to position **ON** .
- Press the **MODE** button repeatedly until the **ODO** mode is active.
- Keep the **MODE** button and the **SET** button pressed simultaneously.
 - ✓ The time display begins to flash.
- Press the **MODE** button to set the hour.
- Press the **SET** button to set the minute.

- Keep the **MODE** button and the **SET** button pressed simultaneously.
 - ✓ The time is set.



6.10.10 ODO display

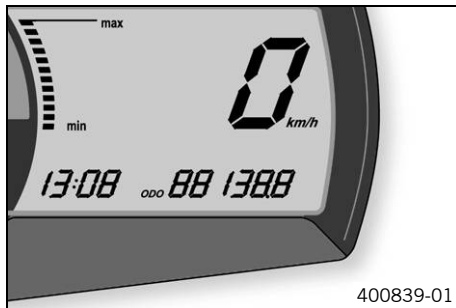

In the **ODO** display mode, the total distance traveled is shown in kilometers or miles.

i Info

This value is retained, even if the battery is disconnected from the vehicle and/or the fuse blows.

6.10.11 Setting/resetting display TRIP 1

i Info

The **TRIP 1** trip counter runs constantly and counts up to **999.9**. The trip counter can be used to measure the distance covered during trips or between two refueling stops. After the value **999.9** is reached, the trip counter starts at **0.0** again.

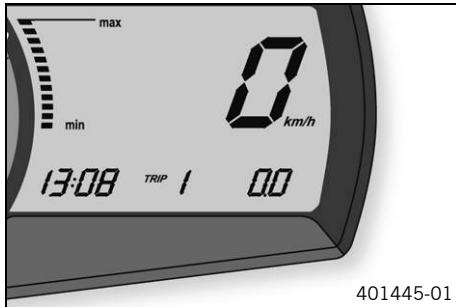



- Switch on the ignition by turning the ignition key to position **ON** .
- Press the **MODE** button repeatedly until the **TRIP 1** mode is active.
- Keep the **SET** button pressed.
 - ✓ The **TRIP 1** display is set to **0.0**.

6.10.12 Setting/resetting display TRIP 2

Info

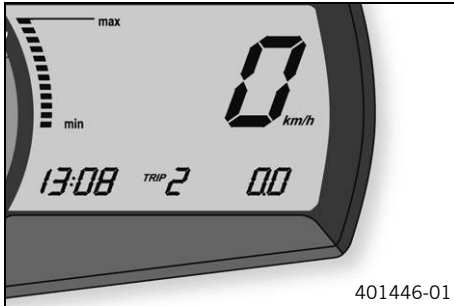
The **TRIP 2** trip counter runs constantly and counts up to **999.9**. The trip counter can be used to measure the distance covered during trips or between two refueling stops. After the value **999.9** is reached, the trip counter starts at **0.0** again.



- Switch on the ignition by turning the ignition key to position **ON** .
- Press the **MODE** button repeatedly until the **TRIP 2** mode is active.
- Keep the **SET** button pressed.
 - ✓ The **TRIP 2** display is set to **0.0**.



6.10.13 TRIP F display

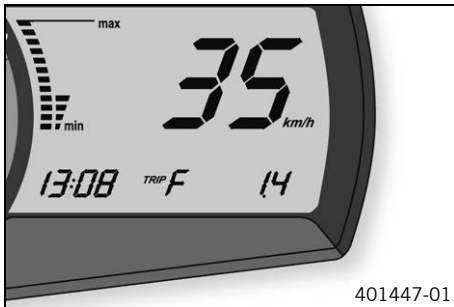

If the fuel level drops to the reserve mark, the display automatically changes to **TRIP F** and starts to count from **0.0**, regardless of the previous display mode.



Info

The low fuel level warning lamp lights up in parallel to the **TRIP F** display.

6 CONTROLS

6.10.14 GEAR display

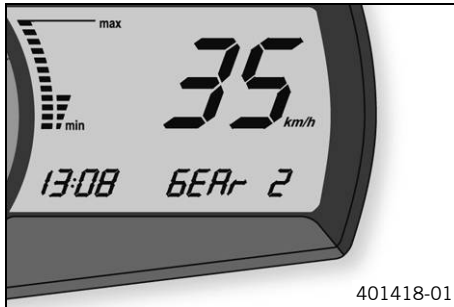

In display mode **GEAR**, the gear currently engaged is displayed.

6.10.15 Coolant temperature indicator

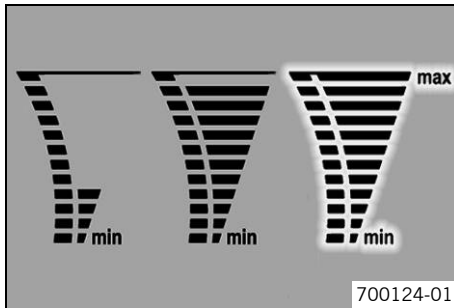

The temperature indicator consists of 12 bars. The more bars that light up, the hotter the coolant. When the upper bar lights up, all bars in the display begin to flash and the temperature warning lamp lights up.

Possible states

- The engine is cold – Up to four bars light up.
- Engine warm – Five to eleven bars light up.
- Engine hot – All twelve bars flash.

6.11 Opening the filler cap



Danger

Fire hazard Fuel is highly flammable.

The fuel in the fuel tank expands when warm and can escape if overfilled.

- Do not refuel the vehicle in the vicinity of open flames or lit cigarettes.
- Switch off the engine for refueling.
- Make sure that no fuel is spilled; particularly not on hot parts of the vehicle.
- If any fuel is spilled, wipe it off immediately.
- Observe the specifications for refueling.



Warning

Danger of poisoning Fuel is poisonous and a health hazard.

- Avoid skin, eye and clothing contact with fuel.
- Immediately consult a doctor if you swallow fuel.
- Do not inhale fuel vapors.
- In case of skin contact, rinse the affected area with plenty of water.
- Rinse the eyes thoroughly with water, and consult a doctor in case of fuel contact with the eyes.
- Change your clothing in case of fuel spills on them.
- Keep fuels correctly in a suitable canister, and out of the reach of children.



Warning

Environmental hazard Improper handling of fuel is a danger to the environment.

- Do not allow fuel to enter the groundwater, the soil, or the sewage system.



- Lift cover **1** of filler cap and insert the ignition key.
- Turn the ignition key 90° counterclockwise and remove the filler cap.



Info

The filler cap has a fuel tank breather.

6.12 Closing filler cap



- Put the filler cap back on and turn the ignition key 90° clockwise.
- Remove the ignition key and fold down the cover.



6.13 Seat unlocking

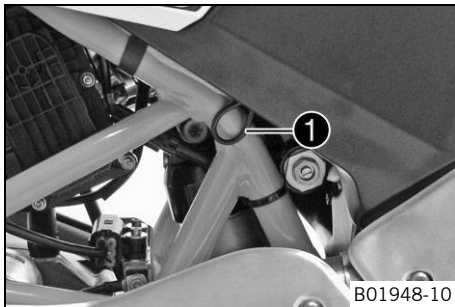

The loop **1** unlocks the seat.

6 CONTROLS

6.14 Handrails



The handrails ❶ are used for moving the motorcycle around. When you have a passenger, the passenger can hold on the handrails during the journey.

6.15 Passenger footrest



The passenger footrests are foldable.

Possible states

- Passenger footrest folded in – For operation without a passenger.
- Passenger footrest folded out – For operation with a passenger.

6.16 Shift lever

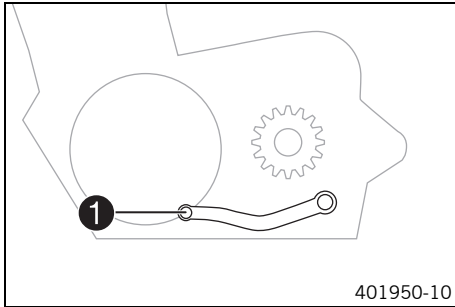

The shift lever ① is mounted on the left side of the engine.

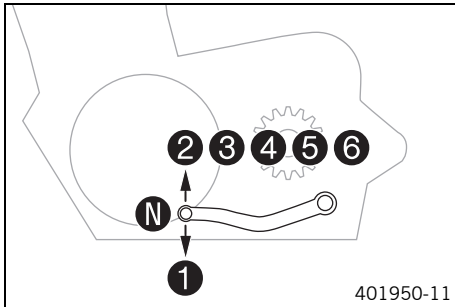

The gear positions can be seen in the photograph.
The neutral or idle position is between the first and second gears.

6.17 Foot brake lever

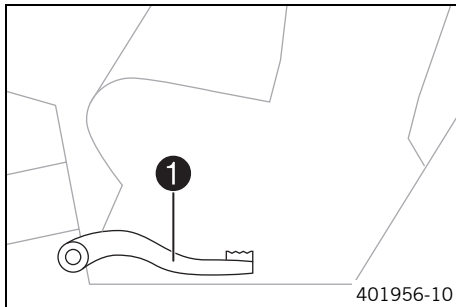

Foot brake lever **1** is located in front of the right footrest. The rear brake is engaged with the foot brake lever.

6.18 Side stand

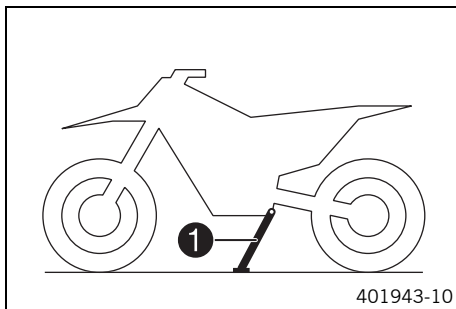

The side stand **1** is located on the left side of the vehicle. The side stand is used for parking the motorcycle.

i Info

The side stand must be folded up during motorcycle use. The side stand is coupled with the safety starting system – see the riding instructions.

Possible states

- Side stand folded out – The vehicle can be supported on the side stand. The safety starting system is active.

- Side stand folded in – This position is mandatory when riding the motorcycle. The safety starting system is inactive.

7.1 Advice on preparing for first use



Danger

Danger of accidents A rider who is not fit to ride poses a danger to him or herself and others.

- Do not operate the vehicle if you are not fit to ride due to alcohol, drugs or medication.
- Do not operate the vehicle if you are physically or mentally impaired.



Warning

Risk of injury Missing or poor protective clothing presents an increased safety risk.

- Wear appropriate protective clothing such as helmet, boots, gloves as well as trousers and a jacket with protectors on all rides.
- Always wear protective clothing that is in good condition and meets the legal regulations.



Warning

Danger of crashing Different tire tread patterns on the front and rear wheel impair the handling characteristic.

Different tire tread patterns can make the vehicle significantly more difficult to control.

- Make sure that only tires with a similar tire tread pattern are fitted to the front and rear wheel.



Warning

Danger of accidents Non-approved or non-recommended tires and wheels impact the handling characteristic.

- Only use tires/wheels approved by KTM with the corresponding speed index.



Warning

Danger of accidents New tires have reduced road grip.

The contact surface on new tires is not yet roughened.

- Run in new tires with moderate riding at alternating angles.
Running-in phase 200 km (124 mi)



Warning

Danger of accidents The brake system fails in the event of overheating.

If the foot brake lever is not released, the brake linings drag continuously.

- Take your foot off the foot brake lever when you are not braking.



Info

When using your vehicle, remember that others may feel disturbed by excessive noise.

- Make sure that the pre-delivery inspection work has been carried out by an authorized KTM workshop.
 - ✓ You receive a delivery certificate and the Service and Warranty Booklet at vehicle handover.
- Before your first trip, read the entire Owner's Manual carefully.
- Get to know the controls.
- Adjust the basic position of the clutch lever. (📖 p. 117)
- Adjust the basic position of the hand brake lever. (📖 p. 124)
- Adjust the basic position of the foot brake lever. 🦶 (📖 p. 137)

7 PREPARING FOR USE

- Get used to handling the motorcycle in a suitable area before making a longer trip. Try also to ride as slowly as possible and in a standing position to get a better feeling for the motorcycle.
- Do not make any trips that exceed your ability and experience.
- Hold the handlebar firmly with both hands and keep your feet on the footrests when riding.
- Run the engine in. (📖 p. 52)

7.2 Running in the engine

- During the running-in phase, do not exceed the specified engine speed.

Guideline

Maximum engine speed	
During the first: 1,000 km (620 mi)	6,000 rpm
After the first: 1,000 km (620 mi)	7,800 rpm

- Avoid fully opening the throttle!

7.3 Loading the vehicle



Warning

Danger of accidents Total weight and axle loads influence the handling characteristic.

The overall weight consists of: motorcycle ready for operation and with a full tank, driver and passenger with protective clothing and helmet, and luggage.

- Do not exceed the maximum permissible overall weight or the axle loads.



Warning

Danger of accidents Improper mounting of cases or the tank rucksack impairs the handling characteristic.

- Mount and secure cases and tank rucksack according to the manufacturer's instructions.



Warning

Danger of accidents Unstable handling characteristics at high speed.

- Adapt your speed according to your payload. Ride more slowly if your motorcycle is loaded with cases or other baggage.

Maximum speed with baggage

130 km/h (80.8 mph)



Warning

Danger of accidents The luggage system will be damaged if it is overloaded.

- Read the manufacturer information on maximum payload when mounting cases.

7 PREPARING FOR USE



Warning

Danger of accidents Luggage which has slipped impairs visibility.

If the tail light is covered, you are less visible to traffic behind you, especially when it is dark.

- Check that your luggage is fixed properly at regular intervals.



Warning

Danger of accidents A high payload alters the handling characteristic and increases the stopping distance.

- Adapt your speed to your payload.



Warning

Danger of accidents Pieces of luggage which have slipped impair the handling characteristic.

- Check that your luggage is fixed properly at regular intervals.



Warning

Fire hazard The hot exhaust system may burn luggage.

- Fasten your luggage in such a way that it cannot be burned or singed by the hot exhaust system.

-
- If you carry luggage, make sure you secure it firmly as close as possible to the center of the vehicle and ensure even weight distribution between the front and rear wheels.
 - Do not exceed the maximum permissible weight and the maximum permissible axle loads.

Guideline

Maximum permissible overall weight	350 kg (772 lb.)
Maximum permissible front axle load	150 kg (331 lb.)
Maximum permissible rear axle load	200 kg (441 lb.)



8.1 Checks and maintenance measures when preparing for use



Info

Before every trip, check the condition of the vehicle and ensure that it is roadworthy. The vehicle must be in perfect technical condition when it is being operated.

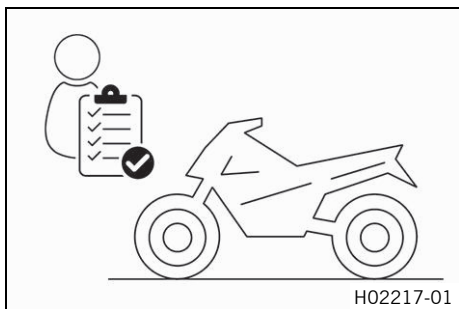

- Check the engine oil level. (📖 p. 207)
- Check the brake fluid level of the front brake. (📖 p. 126)
- Check the rear brake fluid level. (📖 p. 139)
- Check the front brake linings. (📖 p. 130)
- Check the rear brake linings. (📖 p. 142)
- Check that the brake system is functioning properly.
- Check the coolant level. (📖 p. 193)
- Check the chain for dirt. (📖 p. 105)
- Check the chain tension. (📖 p. 107)
- Check the tire condition. (📖 p. 158)
- Check the tire air pressure. (📖 p. 160)
- Check the settings of all controls and ensure that they can be operated smoothly.
- Check that the electrical system is functioning properly.
- Check that luggage is properly secured.
- Sit on the motorcycle and check the rear mirror setting.
- Check the fuel level.

8.2 Starting the vehicle



Danger

- Danger of poisoning** Exhaust gases are toxic and inhaling them may result in unconsciousness and death.
- Always make sure there is sufficient ventilation when running the engine.
 - Use an effective exhaust extraction system when starting or running the engine in an enclosed space.



Caution

- Danger of accidents** Electronic components and safety devices will be damaged if the battery is discharged or missing.
- Never operate the vehicle with a discharged battery or without a battery.

Note

- Engine damage** High revving speed with a cold engine negatively impacts the lifespan of the engine.
- Always run the engine warm at a low speed.

8 RIDING INSTRUCTIONS

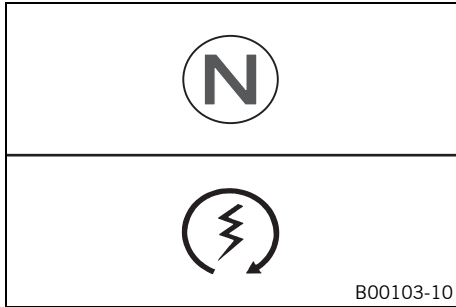

- Turn the emergency OFF switch to the position ○.
- Switch on the ignition by turning the ignition key to position **ON** ○.
 - ✓ After you switch on the ignition, you can hear the fuel pump working for about two seconds. The function check of the combination instrument is run at the same time.
 - ✓ The ABS warning lamp lights up and goes back out after starting off.
- Shift gear to neutral.
 - ✓ The green idle indicator lamp **N** lights up.
- Press the electric starter button Ⓢ.

**Info**

Do not press the electric starter button until the combination instrument function check is finished.

When starting, **DO NOT** open the throttle. If you open the throttle during the starting procedure, fuel is not injected by the engine management system and the engine cannot start.

Press the starter for a maximum of 5 seconds. Wait for a least 5 seconds before trying again.

This motorcycle is equipped with a safety starting system. You can only start the engine if the transmission is in neutral or if the clutch lever is pulled when a gear is engaged. If the side stand is folded out and you shift into gear and release the clutch, the engine stops.

-
- Take the weight off the side stand and swing it back up with your foot as far as it will go.

8 RIDING INSTRUCTIONS

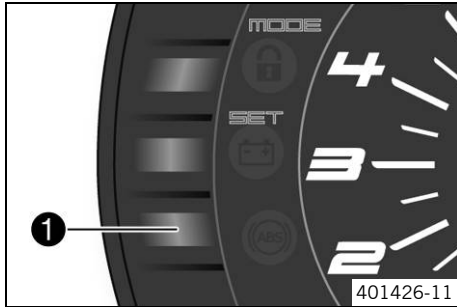

Switching off ABS

KTM recommends riding with ABS at all times. However, situations may arise in which ABS is not advantageous.

Condition

Vehicle stationary, engine running.

- Press button ① for 3 – 5 seconds.
- ✓ The ABS warning lamp starts flashing; ABS is deactivated.

8.3 Starting off

- Pull the clutch lever, engage 1st gear, release the clutch lever slowly and simultaneously open the throttle carefully.

8.4 Shifting, riding



Warning

Danger of accidents Abrupt load alterations can cause the vehicle to get out of control.

- Avoid abrupt load alterations and sudden braking actions.
- Adapt your speed to the road conditions.

**Warning**

Danger of accidents If you change down at high engine speed, the rear wheel blocks and the engine races.

- Do not change into a low gear at high engine speed.

**Warning**

Danger of accidents An incorrect ignition key position causes malfunctions.

- Do not change the ignition key position while driving.

**Warning**

Danger of accidents Adjustments to the vehicle distract attention from traffic activity.

- Make all adjustments when the vehicle is at a standstill.

**Warning**

Risk of injury The passenger may fall from the motorcycle if they conduct themselves incorrectly.

- Ensure that the passenger sits correctly on the passenger seat, places his or her feet on the passenger foot rest and holds on to the rider or the grab handles.
- Note the regulations governing the minimum age of passengers in your country.

**Warning**

Danger of accidents A risky riding style constitutes a major risk.

- Comply with traffic regulations and ride defensively and with foresight to detect sources of danger as early as possible.

8 RIDING INSTRUCTIONS



Warning

Danger of accidents Cold tires have reduced road grip.

- Ride the first miles carefully on every journey at moderate speed until the tires reach operating temperature.



Warning

Danger of accidents New tires have reduced road grip.

The contact surface on new tires is not yet roughened.

- Run in new tires with moderate riding at alternating angles.
Running-in phase 200 km (124 mi)



Warning

Danger of accidents Total weight and axle loads influence the handling characteristic.

The overall weight consists of: motorcycle ready for operation and with a full tank, driver and passenger with protective clothing and helmet, and luggage.

- Do not exceed the maximum permissible overall weight or the axle loads.



Warning

Danger of accidents Pieces of luggage which have slipped impair the handling characteristic.

- Check that your luggage is fixed properly at regular intervals.

**Warning**

Danger of accidents A fall can damage the vehicle more seriously than it may first appear.

- Check the vehicle after a fall as you do when preparing for use.

Note

Engine damage Unfiltered intake air has a negative effect on the service life of the engine.

Dust and dirt will enter the engine without an air filter.

- Never start to use the vehicle without an air filter.

Note

Engine failure Overheating damages the engine.

- If the coolant temperature warning is displayed, stop immediately and take care not to endanger yourself or other traffic participants in the process.
 - Allow the engine and cooling system to cool down.
 - Check and, if necessary, correct the coolant level on the cooling system while it is in a cooled state.
-
-

**Info**

If unusual noises arise during operation, stop immediately, switch off the engine, park the vehicle properly, and contact an authorized KTM workshop.

8 RIDING INSTRUCTIONS

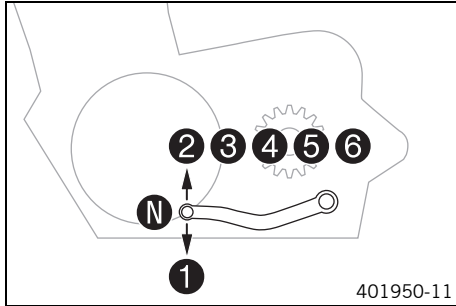

- Shift into a higher gear when conditions allow (incline, road situation, etc.).
- Release the throttle while simultaneously pulling the clutch lever, shift into the next gear, release the clutch lever, and open the throttle.

i Info

You can see the positions of the 6 forward gears in the figure. The neutral or idle position is between the first and second gears. First gear is used for starting off or for steep inclines.

The operating temperature is reached when 5 bars of the temperature indicator light up.

-
- After reaching maximum speed by fully opening the throttle grip, turn the throttle back so it is $\frac{3}{4}$ open. This will barely reduce the speed but fuel consumption will be considerably lower.
 - Accelerate only up to a speed suitable for the road surface and weather conditions. Particularly in bends, do not shift, and accelerate very carefully.
 - Brake if necessary and close the throttle at the same time in order to shift down.
 - Pull the clutch lever and shift into a lower gear, release the clutch lever slowly, and open the throttle or shift again.

- If the engine stalls (e.g. at a crossroads), just pull the clutch lever and press the electric starter button. You do not have to shift into neutral.
- Switch off the engine if running at idle or stationary for a long time.
- Avoid frequent and longer slipping of the clutch. This heats the engine oil, the engine, and the cooling system.
- Ride at a low engine speed instead of at a high engine speed with a slipping clutch.
- Stop immediately taking care not to endanger yourself or other road users if the malfunction indicator lamp lights up during a trip. When you shift to neutral, the malfunction indicator lamp starts to flash.

**Info**

You can deduce a two-digit number from the flash rhythm – the so-called blink code. The blink code tells you which component is affected by a malfunction.



8.5 Applying the brakes



Warning

Danger of accidents Moisture and dirt impair the brake system.

- Brake carefully several times to dry out and remove dirt from the brake linings and the brake discs.



Warning

Danger of accidents A spongy pressure point on the front or rear brake reduces braking efficiency.

- Check the brake system and do not continue riding until the problem is eliminated. (Your authorized KTM workshop will be glad to help.)



Warning

Danger of accidents The brake system fails in the event of overheating.

If the foot brake lever is not released, the brake linings drag continuously.

- Take your foot off the foot brake lever when you are not braking.



Warning

Danger of accidents Higher total weight increases the stopping distance.

- Take the longer stopping distance into account when carrying a passenger or luggage with you.



Warning

Danger of accidents Salt on the roads impairs the brake system.

- Brake carefully several times to remove salt from the brake linings and the brake discs.

**Warning**

Danger of accidents ABS may increase the stopping distance in certain situations.

- Adjust application of the brakes to the respective riding situation and riding surface conditions.

**Warning**

Danger of accidents Excessively forceful application of the brakes blocks the wheels.

The ABS effectiveness is only ensured if it is switched on.

- Leave the ABS switched on in order to benefit from the protective effect.

**Warning**

Danger of accidents The rear wheel can lock due to the engine braking effect.

- Pull in the clutch, if you perform emergency or full braking, or if you brake on a slippery ground.

-
- When braking, release the throttle and apply the front and rear brakes at the same time.

**Info**

When the ABS is enabled, you can achieve maximum braking power even on low grip surfaces such as sandy, wet, or slippery terrain without locking of the wheels.

**Warning**

Danger of accidents Banked or laterally sloping ground reduces the maximum possible delay.

- If possible finish braking before going into a bend.

-
- Always finish braking before you go into a bend. Change down to a lower gear appropriate to your road speed.

8 RIDING INSTRUCTIONS

- Use the braking effect of the engine on long downhill stretches. Change down one or two gears, but do not over-rev the engine. You will have to apply the brakes far less frequently as a result and the brake system will not overheat.

8.6 Stopping, parking



Warning

Risk of injury People who act without authorization endanger themselves and others.

- Do not leave the vehicle unattended if the engine is running.
- Protect the vehicle against access by unauthorized persons.
- Lock the steering and remove the ignition key if you leave the vehicle unattended.



Warning

Danger of burns Some vehicle components become very hot when the vehicle is operated.

- Do not touch any parts such as the exhaust system, radiator, engine, shock absorber, or brake system before the vehicle parts have cooled down.
- Let the vehicle parts cool down before you perform any work on the vehicle.

Note

Material damage The vehicle may be damaged by incorrect procedure when parking.

Significant damage may be caused if the vehicle rolls away or falls over.

The components for parking the vehicle are designed only for the weight of the vehicle.

- Park the vehicle on a firm and level surface.
- Ensure that nobody sits on the vehicle when the vehicle is parked on a stand.

Note

Fire hazard Hot vehicle components pose a fire hazard and explosion risk.

- Do not park the vehicle near to materials which are highly flammable or explosive.
 - Allow the vehicle to cool down before covering it.
-

- Apply the brakes on the motorcycle.
 - Shift gear to neutral.
 - Switch off the ignition by turning the ignition key to position **OFF** ☒.
-

**Info**

If the engine is switched off with the emergency OFF switch and the ignition remains switched on at the ignition lock, power continues to flow to most power consumers. This discharges the battery. You should therefore always switch off the engine with the ignition lock – the emergency OFF switch is intended for emergencies only.

- Park the motorcycle on a firm surface.
 - Swing the side stand forward with your foot as far as it will go and lean the vehicle on it.
 - Lock the steering by turning the handlebar fully to the left, pressing down the ignition key to position ☒ and turning it to position ☑. To make the steering lock engage more easily, move the handlebar a little to the left and right. Remove the ignition key.
-



8 RIDING INSTRUCTIONS

8.7 Transport

Note

Danger of damage The parked vehicle can roll away or fall over.

- Park the vehicle on a firm and level surface.

Note

Fire hazard Hot vehicle components pose a fire hazard and explosion risk.

- Do not park the vehicle near to materials which are highly flammable or explosive.
- Allow the vehicle to cool down before covering it.

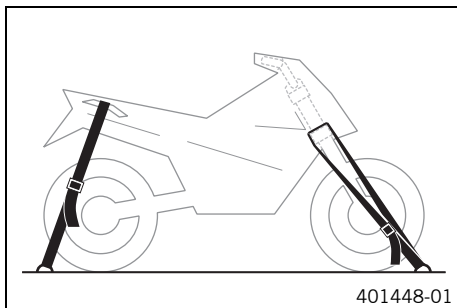

- Switch off the engine and remove the ignition key.
- Use tension belts or other suitable devices to secure the motorcycle against accidents or falling over.

8.8 Refueling



Danger

Fire hazard Fuel is highly flammable.

The fuel in the fuel tank expands when warm and can escape if overfilled.

- Do not refuel the vehicle in the vicinity of open flames or lit cigarettes.
- Switch off the engine for refueling.
- Make sure that no fuel is spilled; particularly not on hot parts of the vehicle.
- If any fuel is spilled, wipe it off immediately.
- Observe the specifications for refueling.



Warning

Danger of poisoning Fuel is poisonous and a health hazard.

- Avoid skin, eye and clothing contact with fuel.
- Immediately consult a doctor if you swallow fuel.
- Do not inhale fuel vapors.
- In case of skin contact, rinse the affected area with plenty of water.
- Rinse the eyes thoroughly with water, and consult a doctor in case of fuel contact with the eyes.
- Change your clothing in case of fuel spills on them.

Note

Material damage Inadequate fuel quality causes the fuel filter to quickly become clogged.

8 RIDING INSTRUCTIONS

In some countries and regions, the available fuel quality and cleanliness may not be sufficient. This will result in problems with the fuel system.

- Refuel only with clean fuel that meets the specified standards. (Your authorized KTM workshop will be glad to help.)



Warning

Environmental hazard Improper handling of fuel is a danger to the environment.

- Do not allow fuel to enter the groundwater, the soil, or the sewage system.

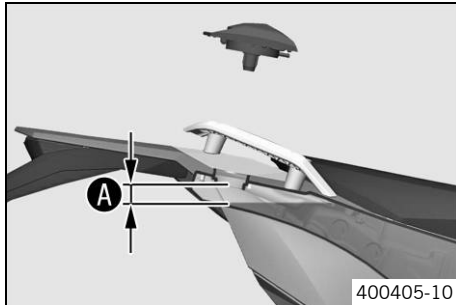

- Switch off the engine.
- Open the filler cap. (📖 p. 43)
- Fill the fuel tank with fuel up to level **A**.

Guideline

Level A	20 mm (0.79 in)	
Total fuel tank capacity, approx.	12 l (3.2 US gal)	Super unleaded (ROZ 95/RON 95/PON 91) (📖 p. 260)

- Close the filler cap. (📖 p. 45)

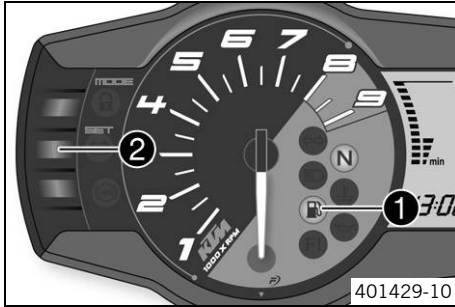

- Press the **SET** button **2** for two seconds.
- ✓ The fuel level warning lamp **1** goes out. **TRIP F** is set to **0.0** and the display returns to the previous display mode.



Info

If you do not press the **SET** button **2**, the reset takes place automatically after approx. three minutes.

9 SERVICE SCHEDULE







9.1 Additional information

Any further work that results from the required work or from the recommended work must be ordered separately and can be invoiced separately.

Different service intervals may apply in your country, depending on the local operating conditions.

Individual service intervals and scopes may change in the course of technical developments. The most up-to-date service schedule can always be found on KTM Dealer.net. Your authorized KTM dealer will be happy to advise you.

9.2 Required work

	after every sporting use					
	Every two years					
	Every year					
	every 20,000 km (12,400 mi)					
	every 10,000 km (6,200 mi)					
	after 1,000 km (620 mi)					
Read out the fault memory using the KTM diagnostics tool. 	○	●	●	●	●	●
Check that the electrical system is functioning properly.	○	●	●	●	●	●
Change the engine oil and filter, clean the oil screens.   p. 208	○	●	●	●	●	●
Check the front brake linings.  p. 130	○	●	●	●	●	●
Check the rear brake linings.  p. 142	○	●	●	●	●	●
Check the brake discs.  p. 125	○	●	●	●	●	●
Check the brake lines for damage and leakage.	○	●	●	●	●	●

	after every sporting use				
	Every two years				
	Every year				
	every 20,000 km (12,400 mi)				
	every 10,000 km (6,200 mi)				
	after 1,000 km (620 mi)				
Change the front brake fluid. 🛞					•
Change the rear brake fluid. 🛞					•
Change the hydraulic clutch fluid. 🛞					•
Check the brake fluid level of the front brake. (🛞 p. 126)	○	•	•	•	•
Check the rear brake fluid level. (🛞 p. 139)	○	•	•	•	•
Check/correct the fluid level of the hydraulic clutch. (🛞 p. 118)		•	•	•	•
Check the free travel of the foot brake lever. (🛞 p. 136)	○	•	•	•	•
Check the shock absorber and fork for leaks. Perform a fork service and shock absorber service as needed and depending on how the vehicle is used.	○	•	•	•	•
Clean the dust boots of the fork legs. (🛞 p. 96)		•	•		•
Check the play of the steering head bearing. (🛞 p. 99)	○	•	•	•	•
Check the tire condition. (🛞 p. 158)	○	•	•	•	•
Check the tire air pressure. (🛞 p. 160)	○	•	•	•	•
Check the spoke tension. (🛞 p. 162)	○	•	•	•	•
Check the rim run-out. 🛞	○	•	•	•	•
Check the chain, rear sprocket, engine sprocket, and chain guide. (🛞 p. 111)		•	•	•	•

9 SERVICE SCHEDULE

	after every sporting use					
		Every two years				
			Every year			
				every 20,000 km (12,400 mi)		
					every 10,000 km (6,200 mi)	
						after 1,000 km (620 mi)
Check the chain tension. (📖 p. 107)	○	●	●	●	●	●
Change the fuel screen. 🛠️	○	●	●	●	●	
Change the spark plug. 🛠️			●			
Check the valve clearance. 🛠️		●	●			
Check the antifreeze and coolant level. (📖 p. 190)	○	●	●	●	●	●
Check the cables for damage and for routing without kinks. 🛠️		●	●	●	●	●
Change the air filter. Clean the air filter box. 🛠️		●	●			●
Check the fuel pressure. 🛠️		●	●	●	●	
Check the headlight setting. (📖 p. 186)	○	●	●			●
Check that the radiator fan is functioning properly. 🛠️	○	●	●	●	●	●
Final check: Check the vehicle is roadworthy and take a test ride. 🛠️	○	●	●	●	●	●
Read out the fault memory using the KTM diagnostics tool after a test ride. 🛠️	○	●	●	●	●	●
Check the CO adjustment using the KTM diagnostics tool. 🛠️		●	●			●
Make the service entry in KTM Dealer.net and in the Service and Manufacturer Warranty Booklet. 🛠️	○	●	●	●	●	●

- One-time interval
- Periodic interval

9.3 Recommended work

	after every sporting use					
	Every four years		Every year			
	every 30,000 km (18,600 mi)					
	every 10,000 km (6,200 mi)					
	after 1,000 km (620 mi)					
Check the frame. 🛠️			●			
Check the swingarm. 🛠️			●			
Check the swingarm bearing for play. 🛠️		●	●			
Check the wheel bearing for play. 🛠️		●	●			●
Grease all moving parts (e.g. side stand, hand lever, chain, etc.) and check for smooth operation. 🛠️	○	●	●	●	●	●
Check all hoses (e.g. fuel, cooling, bleeder, drainage, etc.) and sleeves for cracking, leaks, and incorrect routing. 🛠️		●	●	●	●	●
Check the screws and nuts for tightness. 🛠️	○	●	●	●	●	●
Change the coolant. 🛠️ (📖 p. 199)					●	

- One-time interval
- Periodic interval

10 TUNING THE CHASSIS

10.1 Fork/shock absorber

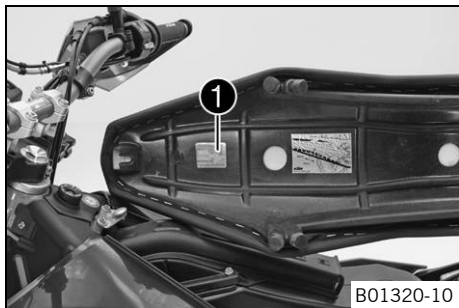

The fork and the shock absorber offer many options of adapting the chassis to your riding style and the payload.



Info

To help you adapt the vehicle, we have summarized our findings in Table 1. You can find the table on the underside of the seat.

These adjustments should be understood as a guideline and should always be the basis of your own personal suspension setting. Do not change the adjustments at random or by more than $\pm 40\%$, since otherwise the riding characteristics could deteriorate, particularly at high speeds.

10.2 Adjusting the compression damping of the fork



Info

The hydraulic compression damping determines the fork suspension behavior.

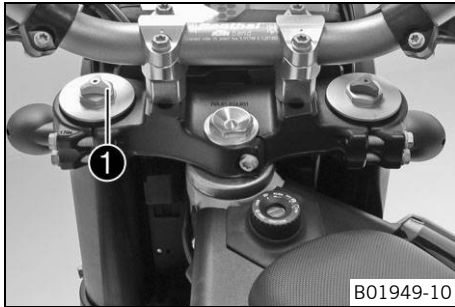

- Turn the white adjusting screw **1** all the way clockwise.

i **Info**
 Adjusting screw **1** is located at the upper end of the left fork leg.
 The compression damping is located in the left fork leg **COMP** (white adjusting screw). The rebound damping is located in the right fork leg **REB** (red adjusting screw).

- Turn counterclockwise by the number of clicks corresponding to the fork type.

Guideline

Compression damping	
Comfort	20 clicks
Standard	15 clicks
Sport	10 clicks
Full payload	10 clicks

i **Info**
 Turn clockwise to increase damping; turn counterclockwise to reduce damping.



10.3 Adjusting the rebound damping of the fork



Info

The hydraulic rebound damping determines the fork rebound behavior.

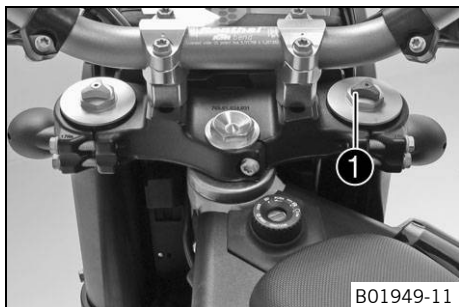

- Turn the red adjusting screw ① all the way clockwise.



Info

Adjusting screw ① is located at the upper end of the right fork leg.

The rebound damping is located in the right fork leg **REB** (red adjusting screw). The compression damping is located in the left fork leg **COMP** (white adjusting screw).

- Turn counterclockwise by the number of clicks corresponding to the fork type.

Guideline

Rebound damping	
Comfort	20 clicks
Standard	15 clicks
Sport	10 clicks
Full payload	10 clicks

**Info**

Turn clockwise to increase damping; turn counterclockwise to reduce damping.



10.4 Compression damping of the shock absorber

The compression damping of the shock absorber is divided into two ranges: high-speed and low-speed. High-speed and low-speed refer to the compression speed of the rear wheel suspension and not to the vehicle speed.

The high-speed setting, for example, has an effect when riding over an asphalt edge: the rear wheel suspension compresses quickly.

The low-speed setting, for example, has an effect when riding over long ground swells: the rear wheel suspension compresses slowly.

These two ranges can be adjusted separately, although the transition between high-speed and low-speed is gradual. Thus, changes in the high-speed range affect the compression damping in the low-speed range and vice versa.

10.5 Adjusting the low-speed compression damping of the shock absorber

**Caution**

Risk of injury Parts of the shock absorber will move around if the shock absorber is detached incorrectly. The shock absorber is filled with highly compressed nitrogen.

- Please follow the description provided. (Your authorized KTM workshop will be glad to help.)
-

i Info

The effect of the low-speed setting can be seen in slow to normal compression of the shock absorber.

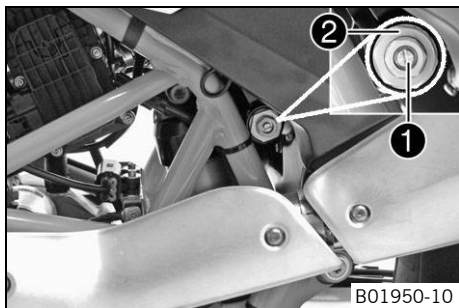

- Turn adjusting screw ① clockwise with a screwdriver up to the last perceptible click.

i Info

Do not loosen fitting ②!

- Turn counterclockwise by the number of clicks corresponding to the shock absorber type.

Guideline

Compression damping, low-speed	
Comfort	20 clicks
Standard	15 clicks
Sport	10 clicks
Full payload	10 clicks

i Info

Turn clockwise to increase damping; turn counterclockwise to reduce damping.

10.6 Adjusting the high-speed compression damping of the shock absorber



Caution

Risk of injury Parts of the shock absorber will move around if the shock absorber is detached incorrectly. The shock absorber is filled with highly compressed nitrogen.

- Please follow the description provided. (Your authorized KTM workshop will be glad to help.)



Info

The effect of the high-speed setting can be seen in fast compression of the shock absorber.

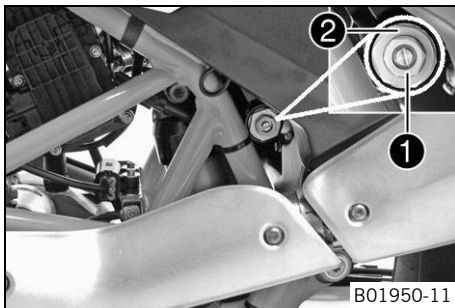

B01950-11

- Turn adjusting screw **1** all the way clockwise with a socket wrench.



Info

Do not loosen fitting **2**!

- Turn counterclockwise by the number of turns corresponding to the shock absorber type.

Guideline

Compression damping, high-speed	
Comfort	2 turns
Standard	1.5 turns
Sport	1 turn
Full payload	1 turn



Info

Turn clockwise to increase damping; turn counterclockwise to reduce damping.

10.7 Adjusting the rebound damping of the shock absorber



Caution

Risk of injury Parts of the shock absorber will move around if the shock absorber is detached incorrectly. The shock absorber is filled with highly compressed nitrogen.

- Please follow the description provided. (Your authorized KTM workshop will be glad to help.)

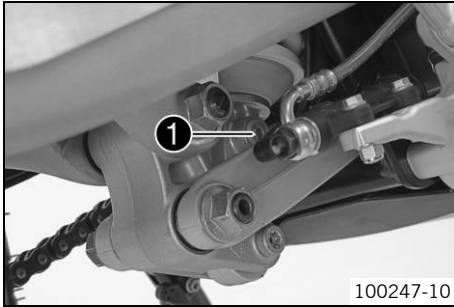

- Turn adjusting screw ❶ clockwise up to the last perceptible click.
- Turn counterclockwise by the number of clicks corresponding to the shock absorber type.

Guideline

Rebound damping	
Comfort	20 clicks
Standard	15 clicks
Sport	10 clicks
Full payload	10 clicks



Info

Turn clockwise to increase damping; turn counterclockwise to reduce damping.



10.8 Measuring the unloaded rear wheel sag

Preparatory work

- Raise the motorcycle with a lift stand. (📖 p. 95)

10 TUNING THE CHASSIS

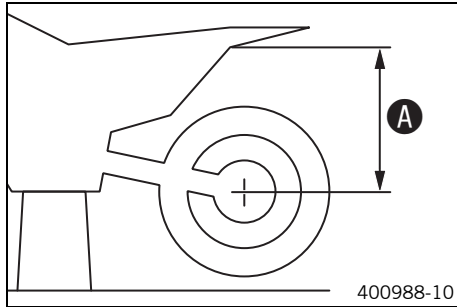

Main work

- Measure the distance – as vertical as possible – between the rear axle and a fixed point, for example, a mark on the rear fairing.
- Note down the value as dimension **A**.

Finishing work

- Remove the motorcycle from the lift stand. (📖 p. 95)

10.9 Checking the static sag of the shock absorber

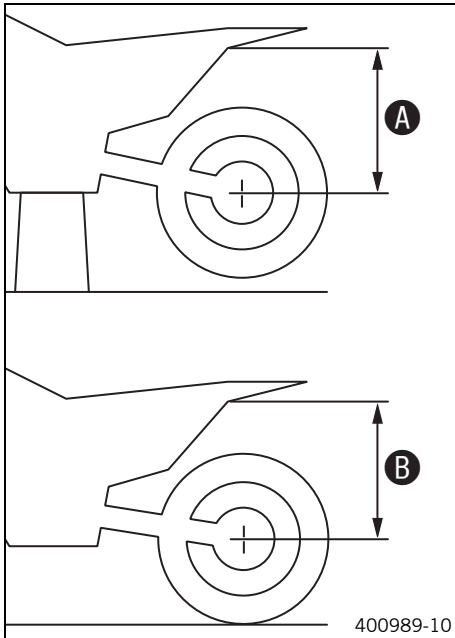

- Measure distance **A** of rear wheel unloaded. (📖 p. 85)
- Hold the motorcycle upright with the aid of an assistant.
- Measure the distance between the rear axle and the fixed point again.
- Note down the value as dimension **B**.



Info

The static sag is the difference between measurements **A** and **B**.

- Check the static sag.

Static sag	18 mm (0.71 in)
------------	-----------------

- » If the static sag is less or more than the specified value:
 - Adjust the spring preload of the shock absorber. 🛠️ (📖 p. 89)

10.10 Checking the riding sag of the shock absorber

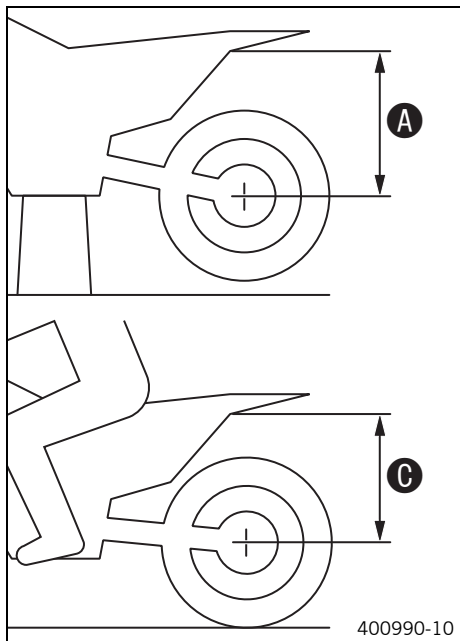

- Measure distance **A** of rear wheel unloaded. (📖 p. 85)
- With another person holding the motorcycle, the rider, wearing full protective clothing, sits on the seat in a normal sitting position (feet on footrests) and bounces up and down a few times.
 - ✓ The rear wheel suspension levels out.
- Another person now measures the distance between the rear axle and a fixed point.
- Note down the value as dimension **C**.



Info

The riding sag is the difference between measurements **A** and **C**.

- Check the riding sag.

Riding sag	70 ... 80 mm (2.76 ... 3.15 in)
------------	---------------------------------

- » If the riding sag differs from the specified measurement:
 - Adjust the riding sag. 🛠️ (📖 p. 91)

10.11 Adjusting the spring preload of the shock absorber



Caution

Risk of injury Parts of the shock absorber will move around if the shock absorber is detached incorrectly. The shock absorber is filled with highly compressed nitrogen.



- Please follow the description provided. (Your authorized KTM workshop will be glad to help.)



Info

Before changing the spring preload, make a note of the present setting, e.g., by measuring the length of the spring.

Preparatory work

- Raise the motorcycle with the work stand.
- Remove the seat. ( p. 102)
- Take off the side cover.
- Remove the shock absorber. 
- After removing the shock absorber, clean it thoroughly.

10 TUNING THE CHASSIS

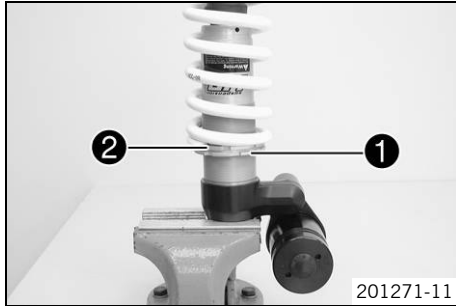

Main work

- Release retaining ring ❶.
- Turn adjusting ring ❷ until the spring is fully relaxed.

Hook wrench (T106S)

- Measure the overall spring length without a load.
- Tighten the spring by turning adjusting ring ❷ to the specified measurement.

Guideline

Spring preload	20 mm (0.79 in)
----------------	-----------------



Info

Depending on the static sag and/or the riding sag, it may be necessary to increase or decrease the spring preload.

- Tighten retaining ring ❶.

Finishing work

- Install the shock absorber. 🛠️
- Mount the side cover.
- Mount the seat. (📖 p. 102)
- Remove the motorcycle from the work stand.

10.12 Adjusting the riding sag 🛠️

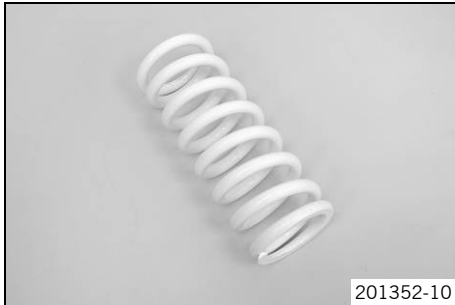

Preparatory work

- Raise the motorcycle with the work stand.
- Remove the seat. (📖 p. 102)
- Take off the side cover.
- Remove the shock absorber. 🛠️
- After removing the shock absorber, clean it thoroughly.

Main work

- Choose and mount a suitable spring.

Guideline

Spring rate	
Medium (standard)	80 N/mm (457 lb/in)
Hard	85 N/mm (485 lb/in)



Info

The spring rate is shown on the outside of the spring.

Finishing work

- Install the shock absorber. 🛠️
- Mount the side cover.
- Mount the seat. (📖 p. 102)
- Remove the motorcycle from the work stand.
- Check the static sag of the shock absorber. (📖 p. 87)

10 TUNING THE CHASSIS

- Adjust the rebound damping of the shock absorber. (📖 p. 84)

10.13 Handlebar position

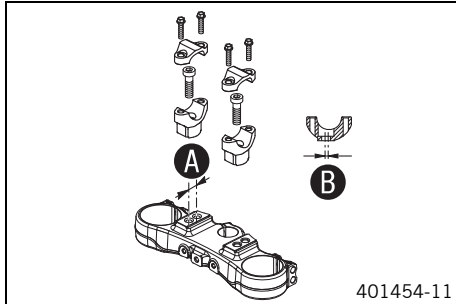

On the upper triple clamp, there are two holes at a distance of **A** to each other.

Hole distance A	15 mm (0.59 in)
------------------------	-----------------

The holes on the handlebar support are placed at a distance of **B** from the center.

Hole distance B	3.5 mm (0.138 in)
------------------------	-------------------

The handlebar can be mounted in 4 different positions. In this way, the handlebar can be mounted in the most comfortable position for the rider.

10.14 Adjusting handlebar position ↩

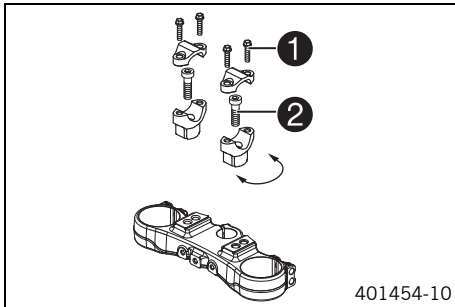

- Remove screws ①. Take off the handlebar clamps. Remove the handlebar and lay it to one side.



Info

Cover the components to protect them against damage. Do not bend the cables and lines.

- Remove screws ②. Remove the handlebar support.
- Place the handlebar support in the required position. Mount and tighten screws ②.

Guideline

Screw, handlebar support	M10	40 Nm (29.5 lbf ft) Loctite®243™
--------------------------	-----	--



Info

Position the left and right handlebar supports evenly.

- Position the handlebar.



Info

Make sure the cables and wiring are positioned correctly.

10 TUNING THE CHASSIS

- Position the handlebar clamps. Mount screws ❶ and tighten evenly.

Guideline

Screw, handlebar clamp	M8	20 Nm (14.8 lbf ft)
------------------------	----	---------------------



11.1 Raising the motorcycle with a lift stand

Note

Danger of damage The parked vehicle can roll away or fall over.

- Park the vehicle on a firm and level surface.

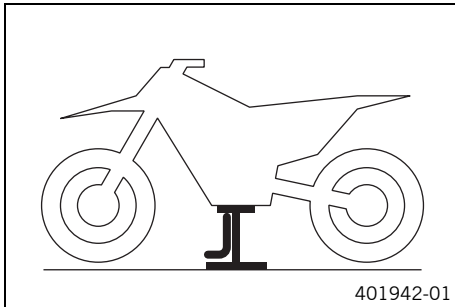

- Use the underide guard underneath the engine to raise the vehicle.
- ✓ Neither wheel is in contact with the ground.
- Secure the motorcycle against falling over.



11.2 Removing the motorcycle from the lift stand

Note

Danger of damage The parked vehicle can roll away or fall over.

- Park the vehicle on a firm and level surface.

11 SERVICE WORK ON THE CHASSIS

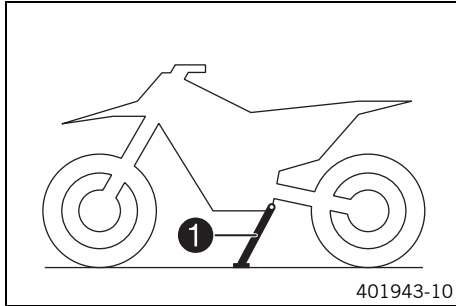

- Remove the motorcycle from the lift stand and rest it on side stand ①.
- Remove the lift stand.

11.3 Cleaning the dust boots of the fork legs

Preparatory work

- Raise the motorcycle with a lift stand. (📖 p. 95)
- Loosen the fork protection. (📖 p. 98)

Main work

- Push dust boots ① of both fork legs downward.



Info

The dust boots remove dust and coarse dirt particles from the inside fork tubes. Over time, dirt can penetrate behind the dust boots. If this dirt is not removed, the oil seals behind the dust boots can start to leak.



Warning

Danger of accidents Oil or grease on the brake discs reduces the braking effect.

- Always keep the brake discs free of oil and grease.
- Clean the brake discs with brake cleaner when necessary.

- Clean and oil the dust boots and inner fork tube of both fork legs.

Universal oil spray (📖 p. 262)

- Press the dust boots back into their normal position.
- Remove excess oil.

Finishing work

- Position the fork protector. (📖 p. 98)
- Remove the motorcycle from the lift stand. (📖 p. 95)



11 SERVICE WORK ON THE CHASSIS

11.4 Loosening the fork protection

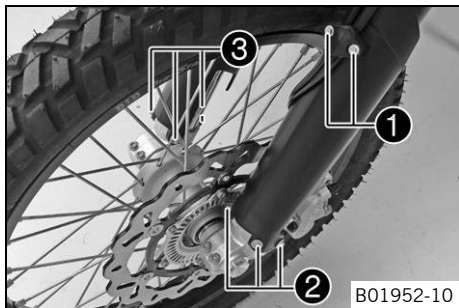

- Remove screws **1** and take off clamp.
- Remove screws **2** on left fork leg. Push the fork protection downwards.
- Remove screws **3** on the right fork leg. Push the fork protector downward.

11.5 Positioning the fork protector

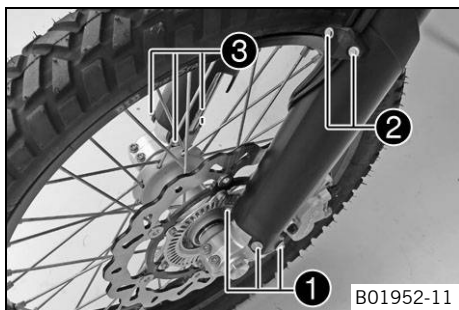

- Position the fork protector on the left fork leg. Mount and tighten screws **1**.

Guideline

Remaining screws, chassis	M6	10 Nm (7.4 lbf ft)
---------------------------	----	--------------------

- Position the brake line, wiring harness, and clamp. Mount and tighten screws **2**.
- Position the fork protector on the right fork leg. Mount and tighten screws **3**.

Guideline

Remaining screws, chassis	M6	10 Nm (7.4 lbf ft)
------------------------------	----	--------------------



11.6 Checking the play of the steering head bearing



Warning

Danger of accidents Incorrect steering head bearing play impairs the handling characteristic and damages components.

- Correct incorrect steering head bearing play immediately. (Your authorized KTM workshop will be glad to help.)



Info

If the vehicle is operated for a lengthy period with play in the steering head bearing, the bearings and the bearing seats in the frame can become damaged over time.

Preparatory work

- Raise the motorcycle with a lift stand. (📖 p. 95)

11 SERVICE WORK ON THE CHASSIS

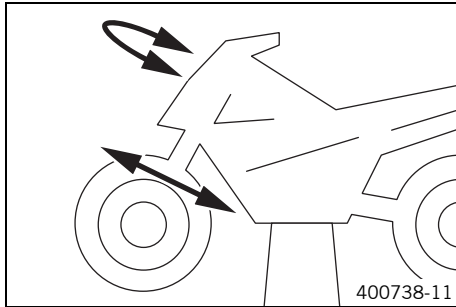

Main work

- Move the handlebar to the straight-ahead position. Move the fork legs to and fro in the direction of travel.

Play should not be detectable on the steering head bearing.

» If there is detectable play:

- Adjust the play of the steering head bearing. 🛠️
(📖 p. 101)

- Move the handlebar to and fro over the entire steering range.

It must be possible to move the handlebar easily over the entire steering range. There should be no detectable detent positions.

» If detent positions are detected:

- Adjust the play of the steering head bearing. 🛠️
(📖 p. 101)
- Check the steering head bearing and adjust if necessary.

Finishing work

- Remove the motorcycle from the lift stand. (📖 p. 95)

11.7 Adjusting the play of the steering head bearing

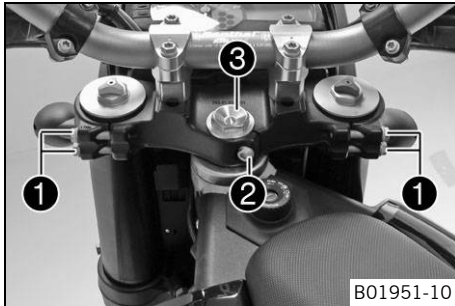

Preparatory work

- Raise the motorcycle with a lift stand. (📖 p. 95)

Main work

- Loosen screw ①. Remove screw ②.
- Loosen and retighten screw ③.

Guideline

Screw, top steering head	M20x1.5	12 Nm (8.9 lbf ft)
--------------------------	---------	--------------------

- Using a plastic hammer, tap lightly on the upper triple clamp to avoid strains.

- Fully tighten screws ①.

Guideline

Screw, top triple clamp	M8	17 Nm (12.5 lbf ft)
-------------------------	----	---------------------

- Mount and tighten screw ②.

Guideline

Screw, steering stem	M8	20 Nm (14.8 lbf ft)
----------------------	----	---------------------

Finishing work

- Check the play of the steering head bearing. (📖 p. 99)
- Remove the motorcycle from the lift stand. (📖 p. 95)



11 SERVICE WORK ON THE CHASSIS

11.8 Removing the seat

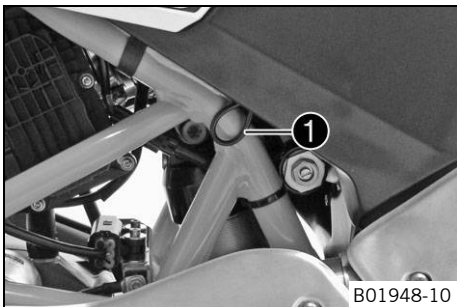

- Pull on strap **1** and raise the rear of the seat at the same time.
- Pull back the seat and lift it off.

11.9 Mounting the seat

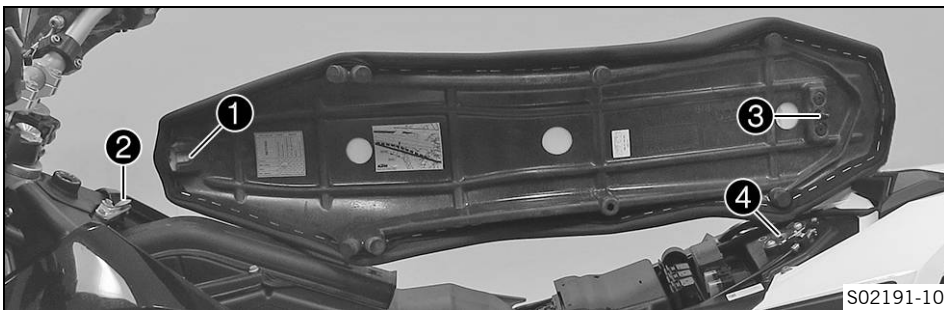

- Hook slot **1** of the seat onto screw **2**, press the rear downward and at the same time push it forward.

- Push locking pin **3** into lock housing **4** and push the back of the seat down until the locking pin locks in place with an audible click.
- Check, finally, that the seat is correctly mounted.



11.10 Removing the air filter

Preparatory work

- Remove the seat. ( p. 102)

Main work

- Remove screws **1**.
- Remove the upper part of the air filter box **2**.

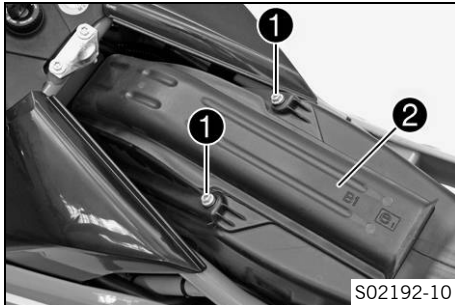

11 SERVICE WORK ON THE CHASSIS

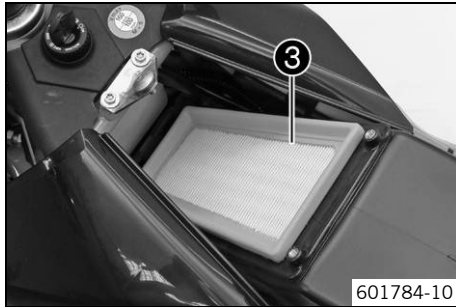

Note

Engine damage Unfiltered intake air has a negative effect on the service life of the engine.

Dust and dirt will enter the engine without an air filter.

- Never start to use the vehicle without an air filter.

- Remove air filter ③.

11.11 Installing the air filter

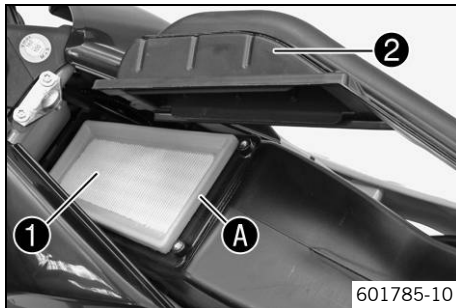

Main work

- Clean the air filter box.
- Mount air filter ①.

Info

The air filter must lie flush against the air filter box along the entire sealing surface A.

If the air filter is not mounted correctly, dust and dirt may enter the engine and result in damage.

- Hook air filter box top ② into the front of the air filter box and swing down.

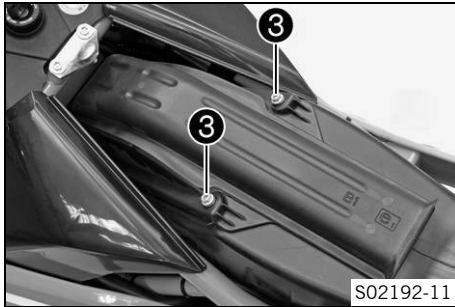

- Mount and tighten screws ③.

Guideline

Screw, air filter box top	M6	2 Nm (1.5 lbf ft)
---------------------------	----	-------------------

Finishing work

- Mount the seat. (📖 p. 102)



11.12 Checking the chain for dirt

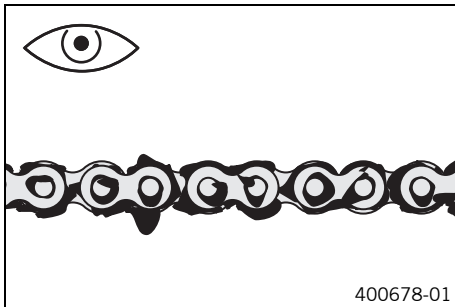

- Check the chain for heavy soiling.
 - » If the chain is very dirty:
 - Clean the chain. (📖 p. 106)



11.13 Cleaning the chain



Warning

Danger of accidents Oil or grease on the tires reduces the road grip.

- Remove the lubricant from the tires using a suitable cleaning agent.



Warning

Danger of accidents Oil or grease on the brake discs reduces the braking effect.

- Always keep the brake discs free of oil and grease.
- Clean the brake discs with brake cleaner when necessary.



Warning

Environmental hazard Hazardous substances cause environmental damage.

- Dispose of oils, grease, filters, fuel, cleaning agents, brake fluid, etc., correctly and in compliance with the applicable regulations.



Info

The service life of the chain depends largely on its maintenance.

Preparatory work

- Raise the motorcycle with a lift stand. (📖 p. 95)

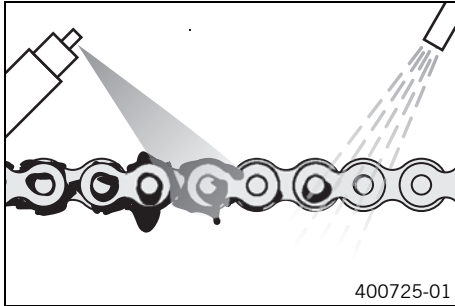

Main work

- Rinse off loose dirt with a soft jet of water.
- Remove old grease residue with chain cleaner.

Chain cleaner (📖 p. 261)

- After drying, apply chain spray.

Off-road chain spray (📖 p. 261)

Finishing work

- Remove the motorcycle from the lift stand. (📖 p. 95)



11.14 Checking the chain tension



Warning

Danger of accidents Incorrect chain tension damages components and results in accidents.

If the chain is tensioned too much, the chain, engine sprocket, rear sprocket, transmission and rear wheel bearings wear more quickly. Some components may break if overloaded.

If the chain is too loose, the chain may fall off the engine sprocket or the rear sprocket. As a result, the rear wheel locks or the engine will be damaged.

- Check the chain tension regularly.
- Set the chain tension in accordance with the specification.

11 SERVICE WORK ON THE CHASSIS

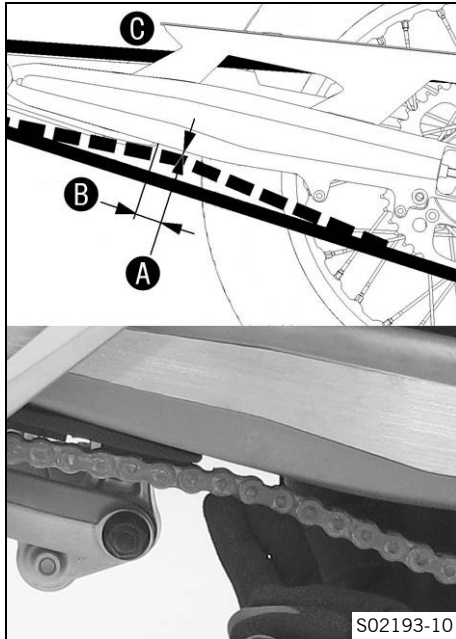

- Lean the motorcycle on the side stand.
- Shift gear to neutral.
- Push the chain upward at a distance **B** from the chain sliding guard and determine the chain tension **A**.

i Info

The upper chain section **C** must be taut. Chain wear is not always even. Repeat this measurement at different chain positions.

Chain tension	5 mm (0.2 in)
Distance to chain sliding guard	30 mm (1.18 in)

- » If the chain tension does not meet specifications:
 - Adjust the chain tension. (📖 p. 109)

11.15 Adjusting the chain tension



Warning

Danger of accidents Incorrect chain tension damages components and results in accidents.

If the chain is tensioned too much, the chain, engine sprocket, rear sprocket, transmission and rear wheel bearings wear more quickly. Some components may break if overloaded.

If the chain is too loose, the chain may fall off the engine sprocket or the rear sprocket. As a result, the rear wheel locks or the engine will be damaged.

- Check the chain tension regularly.
- Set the chain tension in accordance with the specification.

Preparatory work

- Check the chain tension. (📖 p. 107)

11 SERVICE WORK ON THE CHASSIS

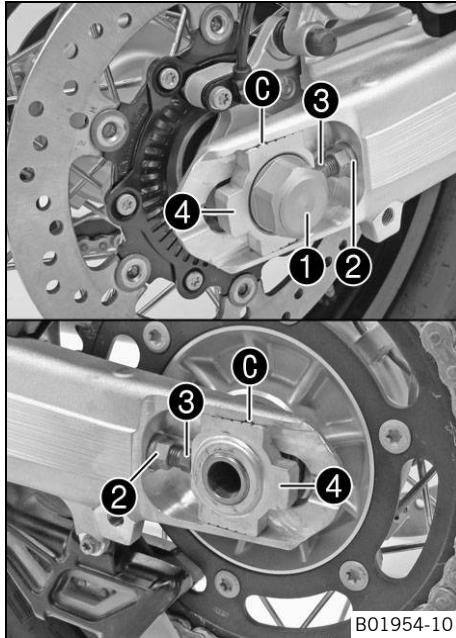

Main work

- Loosen nut ①.
- Loosen nuts ②.
- Adjust the chain tension by turning adjusting screws ③ on the left and right.

Guideline

Chain tension	5 mm (0.2 in)
Turn adjusting screws ③ on the left and right so that the markings on the left and right chain adjusters ④ are in the same position relative to reference marks ⑥. The rear wheel is then correctly aligned.	

Info

The upper chain section must be taut. Chain wear is not always even. Repeat this measurement at different chain positions.

- Tighten nuts ②.
- Make sure that the chain adjusters ④ are installed correctly on adjusting screws ③.
- Tighten nut ①.

Guideline

Nut, rear wheel spindle	M25x1.5	90 Nm (66.4 lbf ft)
-------------------------	---------	---------------------

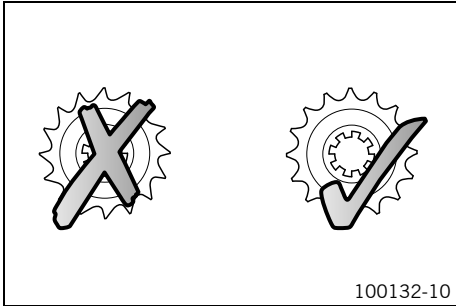
11.16 Checking the chain, rear sprocket, engine sprocket, and chain guide**Preparatory work**

- Raise the motorcycle with a lift stand. (📖 p. 95)

Main work

- Shift the transmission to idle.
- Check the rear sprocket and engine sprocket for wear.
 - » If the rear sprocket or engine sprocket is worn:
 - Change the power set. 🛠

**Info**

The engine sprocket, rear sprocket, and chain should always be replaced together.

11 SERVICE WORK ON THE CHASSIS

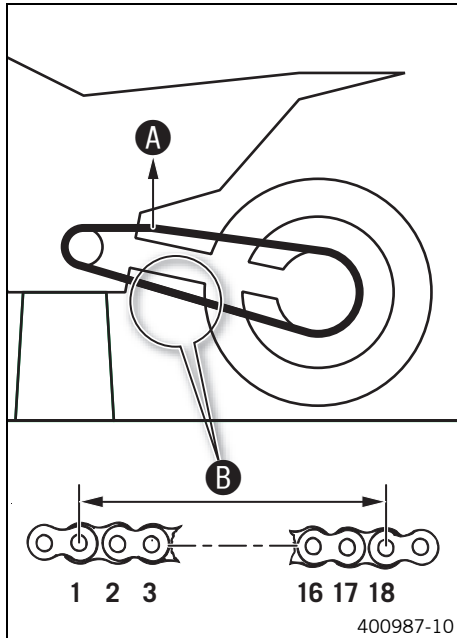

- Pull at the top part of the chain with the specified weight **A**.

Guideline

Weight of chain wear measurement	15 kg (33 lb.)
----------------------------------	----------------

- Measure distance **B** of 18 chain rollers in the lower chain section.



Info

Chain wear is not always even, so you should repeat this measurement at different chain positions.

Maximum distance B at the longest chain section	272 mm (10.71 in)
--	-------------------

- » If the distance **B** is greater than the specified measurement:
 - Change the power set. 🛠



Info

When the chain is replaced, the rear sprocket and engine sprocket should also be changed. New chains wear out faster on an old, worn rear sprocket or engine sprocket.

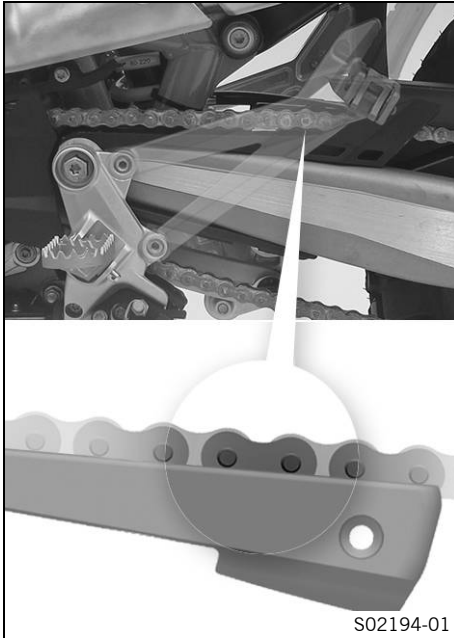

- Check the chain sliding guard for wear.
 - » If the lower edge of the chain pins is in line with or below the chain sliding guard:
 - Replace the chain sliding guard. 🛠️
- Check that the chain sliding guard is firmly seated.
 - » If the chain sliding guard is loose:
 - Tighten the screws on the chain sliding guard.

Guideline

Screw, chain sliding guard	M6	8 Nm (5.9 lbf ft) Loctite®243™
----------------------------	----	--

11 SERVICE WORK ON THE CHASSIS

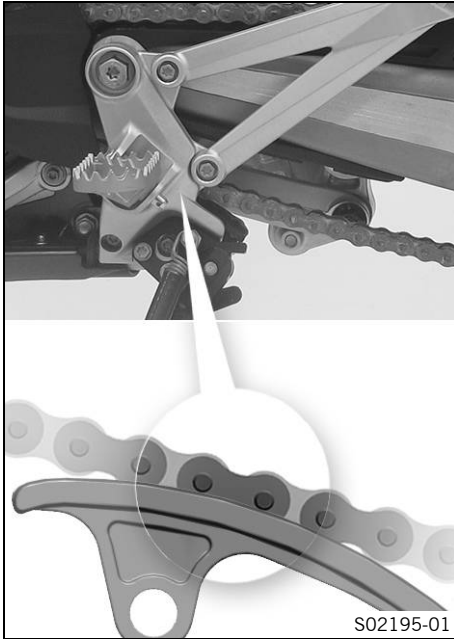

- Check the chain sliding piece for wear.
 - » If the lower edge of the chain pins is in line with or below the chain sliding piece:
 - Change the chain sliding piece. 🛠️
- Check that the chain sliding piece is firmly seated.
 - » If the chain sliding piece is loose:
 - Tighten the screw on the chain sliding piece.

Guideline

Screw, chain sliding piece	M8	15 Nm (11.1 lbf ft)
----------------------------	----	------------------------

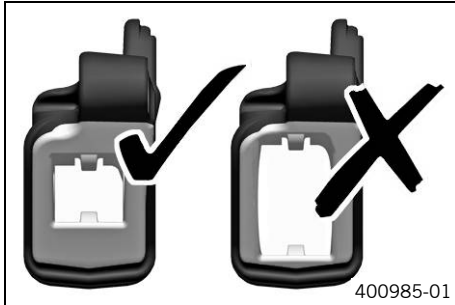

- Check the chain guide for wear.



Info

Wear can be seen on the front of the chain guide.

- » If the light part of the chain guide is worn:
 - Change the chain guide. 🛠️

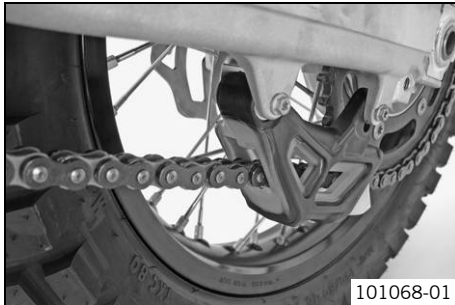

- Check that the chain guide is firmly seated.
 - » If the chain guide is loose:
 - Tighten the screws on the chain guide.

Guideline

Remaining screws, chassis	M6	10 Nm (7.4 lbf ft)
------------------------------	----	-----------------------

Finishing work

- Remove the motorcycle from the lift stand. (📖 p. 95)



11 SERVICE WORK ON THE CHASSIS

11.17 Adjusting chain guide

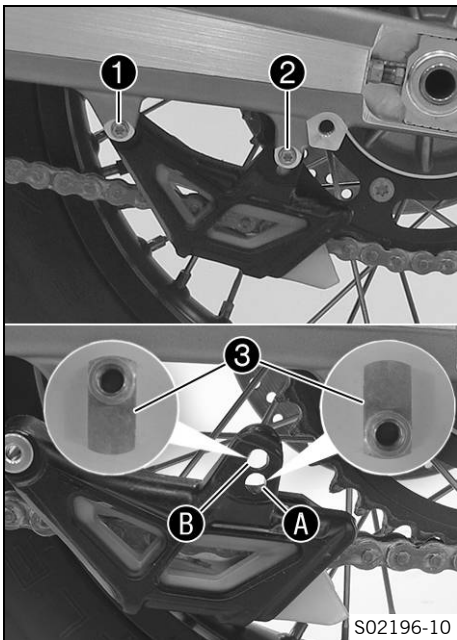

- Remove screws ① and ②. Take off the chain guide.

Condition

Number of teeth: ≤ 44 teeth

- Insert nut ③ in hole ①. Position the chain guide.
- Mount and tighten screws ① and ②.

Guideline

Screw, chain guide	M6	8 Nm (5.9 lbf ft)
--------------------	----	-------------------

Condition

Number of teeth: ≥ 45 teeth

- Insert nut ③ in hole ②. Position the chain guide.
- Mount and tighten screws ① and ②.

Guideline

Screw, chain guide	M6	8 Nm (5.9 lbf ft)
--------------------	----	-------------------

11.18 Adjusting the basic position of the clutch lever

i Info

When the adjusting screw is turned clockwise, the clutch lever moves closer to the handlebar.
 When the adjusting screw is turned counterclockwise, the clutch lever moves away from the handlebar.
 The range of adjustment is limited.
 Turn the adjusting screw by hand only, and do not apply any force.
 Do not make any adjustments while riding.



- Adjust the basic position of the clutch lever to your hand size by turning adjusting screw ①.
- When adjusting the clutch lever, make sure to leave a minimum clearance to other parts of the vehicle.

Guideline

Minimum clearance	5 mm (0.2 in)
-------------------	---------------

11.19 Checking/correcting the fluid level of the hydraulic clutch



Warning

Skin irritation Brake fluid causes skin irritation.

- Keep brake fluid out of the reach of children.
- Wear suitable protective clothing and safety glasses.
- Do not allow brake fluid to come into contact with the skin, the eyes or clothing.
- Consult a doctor immediately if brake fluid has been swallowed.
- Rinse the affected area with plenty of water in the event of contact with the skin.
- Rinse eyes thoroughly with water immediately and consult a doctor if brake fluid comes into contact with the eyes.
- If brake fluid spills on to your clothing, change the clothing.



Warning

Environmental hazard Hazardous substances cause environmental damage.

- Dispose of oils, grease, filters, fuel, cleaning agents, brake fluid, etc., correctly and in compliance with the applicable regulations.



Info

The fluid level rises with increasing wear of the clutch facing discs.

Never use DOT 5 brake fluid. It is silicone-based and purple in color. Oil seals and clutch lines are not designed for DOT 5 brake fluid.

Avoid contact between brake fluid and painted parts. Brake fluid attacks paint.

Only use clean brake fluid from a sealed container.

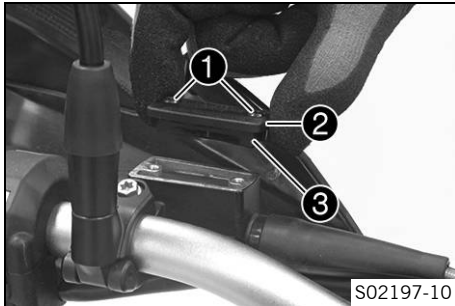

- Move the clutch fluid reservoir mounted on the handlebar to a horizontal position.
- Remove screws ①.
- Remove cover ② with membrane ③.
- Check the fluid level.

Fluid level below container rim	4 mm (0.16 in)
---------------------------------	----------------

- » If the fluid level does not meet specifications:
 - Correct the fluid level of the hydraulic clutch.

Brake fluid DOT 4 / DOT 5.1 (📖 p. 257)
--

- Position the cover with the membrane. Mount and tighten the screws.

11 SERVICE WORK ON THE CHASSIS



Info

Clean up overflowed or spilled brake fluid immediately with water.

11.20 Removing the engine guard



- Remove screws **1** on the left and right.
- Pull the engine guard forward out of the holders and remove it.

11.21 Installing the engine guard

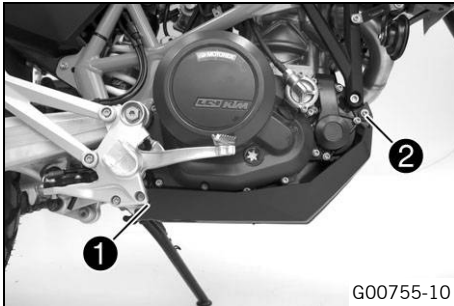

- Slide the engine guard into holders **1** at the rear.
- Position the engine guard. Mount and tighten screws **2**.

Guideline

Remaining screws, chassis	M6	10 Nm (7.4 lbf ft)
------------------------------	----	--------------------

12 BRAKE SYSTEM

12.1 Antilock brake system (ABS)

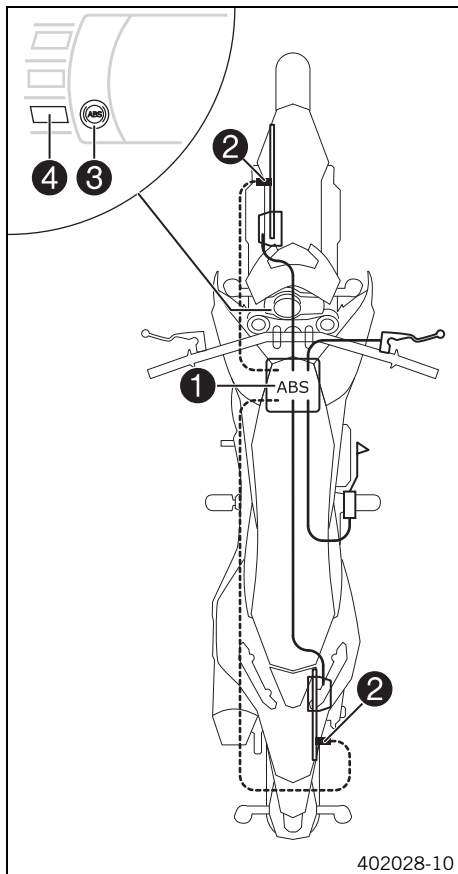

The ABS unit **1**, which consists of a hydraulic unit, ABS control unit, and return pump, is installed under the seat. One wheel speed sensor **2** is located in each case on the front and the rear wheel.



Warning

Danger of accidents Changes to the vehicle impair the function of the ABS.

- Only allow the rear wheel to spin with the front brake applied away from public road traffic if the ABS is switched off.
- Do not make any changes to the suspension travel.
- Only use spare parts on the brake system which have been approved and recommended by KTM.
- Only use tires/wheels approved by KTM with the corresponding speed index.
- Maintain the specified tire air pressure.
- Service work and repairs must be performed professionally. (Your authorized KTM workshop will be glad to help.)

The ABS is a safety system that prevents locking of the wheels when driving straight ahead without the influence of lateral forces.

**Warning**

Danger of accidents Driving aids can only prevent a rollover within the physical limitations.

It is not always possible to compensate for extreme riding situations, for example with luggage loaded with a high center of gravity, varying road surfaces, steep descents or full braking without disengaging the gear.

- Adapt your riding style to the road conditions and your driving ability.

The ABS operates with two independent brake circuits (front and rear brakes). During normal operation, the brake system operates like a conventional brake system without ABS. When the ABS control unit detects a locking tendency in a wheel, ABS begins regulating the brake pressure. The regulating process causes a slight pulsing of the hand and foot brake levers.

The ABS warning lamp **3** must light up after the ignition is switched on and go out after starting off. If it does not go out after starting off or if it lights up while riding, this indicates a fault in the ABS system. In this case, the ABS is no longer enabled and the wheels may lock during braking. The brake system itself stays functional; only ABS control is not available.

The ABS warning lamp may also light up if the rotating speeds of the front and rear wheels differ greatly under extreme riding con-

ditions, for example when making "wheelies" or if the rear wheel spins. This causes the ABS to switch off. To reactivate the ABS, the vehicle must be stopped and the ignition switched off. The ABS is reactivated when the vehicle is switched on again. The ABS warning lamp goes out when you start off.

The button ④ can be used to switch ABS off manually (see Starting).

12.2 Adjusting the basic position of the hand brake lever

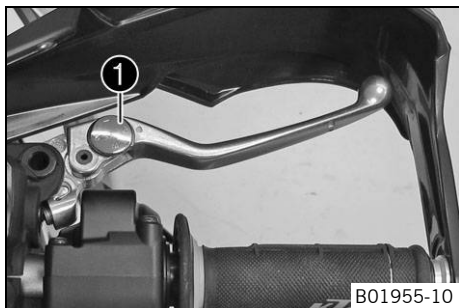

- Adjust the basic position of the hand brake lever to your hand size by turning adjusting wheel ①.



Info

Push the hand brake lever forward and turn the adjusting wheel.
Do not make any adjustments while riding.

12.3 Checking the brake discs



Warning

Danger of accidents Worn-out brake discs reduce the braking effect.

- Make sure that worn-out brake discs are replaced immediately. (Your authorized KTM workshop will be glad to help.)

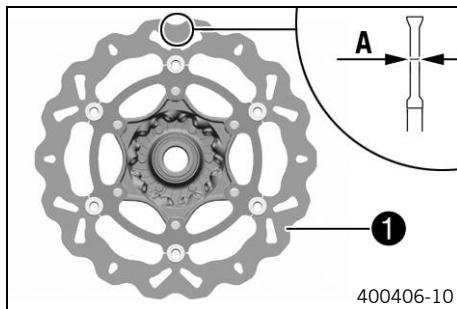

- Check the front and rear brake disc thickness at multiple points for the dimension **A**.



Info

Wear will reduce the thickness of the brake disc at contact surface **1** of the brake linings.

Brake discs - wear limit	
front	4.5 mm (0.177 in)
rear	4.5 mm (0.177 in)

- » If the brake disc thickness is less than the specified value.
 - Change the brake disc.
- Check the front and rear brake discs for damage, cracking, and deformation.
 - » If the brake disc exhibits damage, cracking, or deformation:

- Change the brake disc.

12.4 Checking brake fluid level of front brake



Warning

Danger of accidents An insufficient brake fluid level will cause the brake system to fail.

If the brake fluid level drops below the specified marking or the specified value, the brake system is leaking or the brake linings are worn down.

- Check the brake system and do not continue riding until the problem is eliminated. (Your authorized KTM workshop will be glad to help.)



Warning

Danger of accidents Old brake fluid reduces the braking effect.

- Make sure that brake fluid for the front and rear brake is changed in accordance with the service schedule. (Your authorized KTM workshop will be glad to help.)

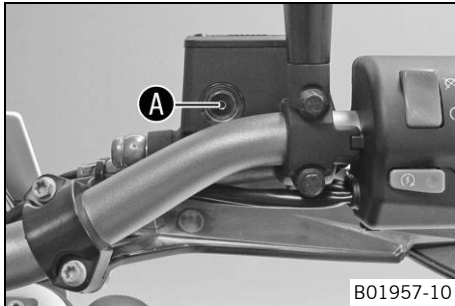

- Move the brake fluid reservoir mounted on the handlebar to a horizontal position.
- Check the brake fluid level in the viewer.
 - » If the brake fluid has dropped below marking **A**:
 - Top up the brake fluid of the front brake. 🛠️
(📖 p. 127)



12.5 Topping up brake fluid of front brake. 🛠️



Warning

Danger of accidents An insufficient brake fluid level will cause the brake system to fail.

If the brake fluid level drops below the specified marking or the specified value, the brake system is leaking or the brake linings are worn down.

- Check the brake system and do not continue riding until the problem is eliminated. (Your authorized KTM workshop will be glad to help.)



Warning

Skin irritation Brake fluid causes skin irritation.

- Keep brake fluid out of the reach of children.
- Wear suitable protective clothing and safety glasses.
- Do not allow brake fluid to come into contact with the skin, the eyes or clothing.
- Consult a doctor immediately if brake fluid has been swallowed.
- Rinse the affected area with plenty of water in the event of contact with the skin.
- Rinse eyes thoroughly with water immediately and consult a doctor if brake fluid comes into contact with the eyes.
- If brake fluid spills on to your clothing, change the clothing.



Warning

Danger of accidents Old brake fluid reduces the braking effect.

- Make sure that brake fluid for the front and rear brake is changed in accordance with the service schedule. (Your authorized KTM workshop will be glad to help.)



Warning

Environmental hazard Hazardous substances cause environmental damage.

- Dispose of oils, grease, filters, fuel, cleaning agents, brake fluid, etc., correctly and in compliance with the applicable regulations.



Info

Never use DOT 5 brake fluid! This is based on silicone oil and is colored purple. Oil seals and brake lines are not designed for DOT 5 brake fluid.

Avoid contact between brake fluid and painted parts. Brake fluid attacks paint!

Use only clean brake fluid from a sealed container.

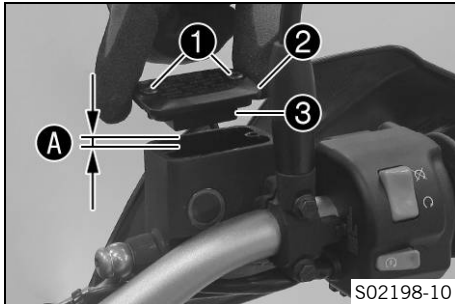

Preparatory work

- Check the front brake linings. (📖 p. 130)

Main work

- Move the brake fluid reservoir mounted on the handlebar to a horizontal position.
- Remove screws ①.
- Remove cover ② with membrane ③.
- Add brake fluid to level A.

Guideline

Level A (brake fluid level below container rim)	5 mm (0.2 in)
---	---------------

Brake fluid DOT 4 / DOT 5.1 (📖 p. 257)
--

- Position the cover with the membrane. Mount and tighten screws.



Info

Clean up overflowed or spilt brake fluid immediately with water.

12.6 Checking the front brake linings



Warning

Danger of accidents Worn-out brake linings reduce the braking effect.

- Ensure that worn-out brake linings are replaced immediately. (Your authorized KTM workshop will be glad to help.)



Warning

Danger of accidents Damaged brake discs reduce the braking effect.

If the brake linings are not changed in time, the brake lining carriers grind against the brake disc. As a consequence, the braking effect is greatly reduced and the brake discs are destroyed.

- Check the brake linings regularly.

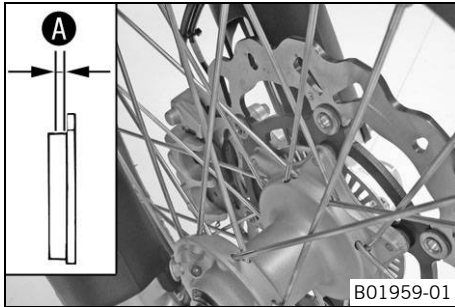

- Check the brake linings for minimum thickness **A**.

Minimum thickness A	$\geq 1 \text{ mm } (\geq 0.04 \text{ in})$
----------------------------	---

- » If the minimum thickness is less than specified:
 - Change the front brake linings. 🛠️ (📖 p. 131)
- Check the brake linings for damage and cracking.
 - » If there is wear or tearing:
 - Change the front brake linings. 🛠️ (📖 p. 131)

12.7 Changing the front brake linings 🛠️



Warning

Danger of accidents Incorrect maintenance will cause the brake system to fail.

- Ensure that service work and repairs are performed professionally. (Your authorized KTM workshop will be glad to help.)



Warning

Skin irritation Brake fluid causes skin irritation.

- Keep brake fluid out of the reach of children.
- Wear suitable protective clothing and safety glasses.
- Do not allow brake fluid to come into contact with the skin, the eyes or clothing.
- Consult a doctor immediately if brake fluid has been swallowed.
- Rinse the affected area with plenty of water in the event of contact with the skin.
- Rinse eyes thoroughly with water immediately and consult a doctor if brake fluid comes into contact with the eyes.
- If brake fluid spills on to your clothing, change the clothing.



Warning

Danger of accidents Old brake fluid reduces the braking effect.

- Make sure that brake fluid for the front and rear brake is changed in accordance with the service schedule. (Your authorized KTM workshop will be glad to help.)



Warning

Danger of accidents Oil or grease on the brake discs reduces the braking effect.

- Always keep the brake discs free of oil and grease.
- Clean the brake discs with brake cleaner when necessary.

**Warning**

Danger of accidents Brake linings which have not been approved alter the braking efficiency.

Not all brake linings are tested and approved for KTM motorcycles. The structure and friction coefficient of the brake linings, and thus their brake power, may vary greatly from that of original brake linings. If brake linings are used that differ from the original equipment, compliance with the original homologation is not guaranteed. In this case, the vehicle no longer corresponds to its condition at delivery and the warranty shall be void.

- Only use brake linings approved and recommended by KTM.

**Warning**

Environmental hazard Hazardous substances cause environmental damage.

- Dispose of oils, grease, filters, fuel, cleaning agents, brake fluid, etc., correctly and in compliance with the applicable regulations.

**Info**

Never use DOT 5 brake fluid! It is silicone-based and purple in color. Oil seals and brake lines are not designed for DOT 5 brake fluid.

Avoid contact between brake fluid and painted parts. Brake fluid attacks paint!

Use only clean brake fluid from a sealed container.

12 BRAKE SYSTEM

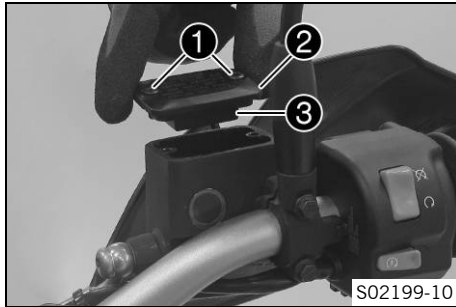

- Move the brake fluid reservoir mounted on the handlebar to a horizontal position.
- Remove screws ❶.
- Remove cover ❷ with membrane ❸.
- Press the brake caliper by hand onto the brake disc in order to retract the brake pistons. Ensure that brake fluid does not flow out of the brake fluid reservoir, extracting it by suction if it does.



Info

Make sure when pushing back the brake pistons that you do not press the brake caliper against the spokes.

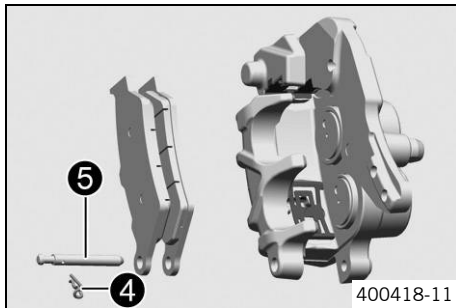

- Remove cotter pin ❹, remove pin ❺ toward the right by striking it, and remove the brake linings.
- Clean brake caliper and brake caliper support.

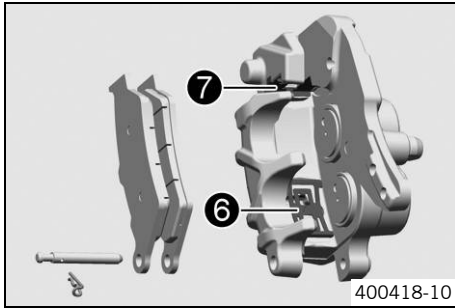

- Check that leaf spring **6** in the brake caliper and sliding plate **7** in the brake caliper support are seated correctly.
- Insert the new brake linings, insert the pin, and mount the cotter pin.



Info

Always change the brake linings in pairs.

- Operate the hand brake lever repeatedly until the brake linings are in contact with the brake disc and there is a pressure point.
- Adjust the brake fluid level to level **A**.

Guideline

Measurement A	5 mm (0.2 in)
----------------------	---------------

Brake fluid DOT 4 / DOT 5.1 (📖 p. 257)
--

- Position the cover with the membrane. Mount and tighten the screws.

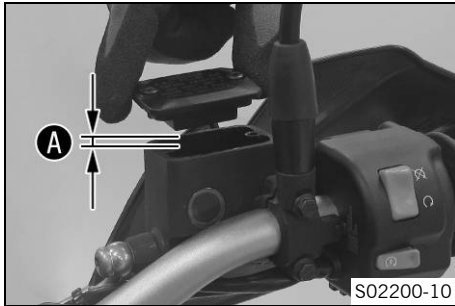

Info

Clean up overflowed or spilt brake fluid immediately with water.



12.8 Checking the free travel of foot brake lever



Warning

Danger of accidents The brake system fails in the event of overheating.

If there is no free travel on the foot brake lever, pressure builds up in the brake system on the rear brake.

- Set the free travel on the foot brake lever in accordance with the specification.

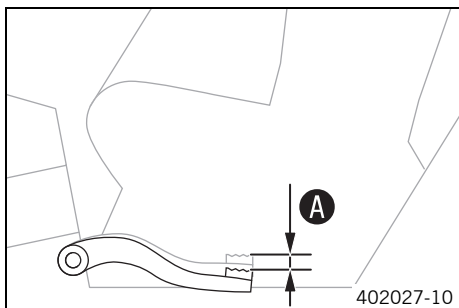

- Move the foot brake lever back and forth between the end stop and the contact to the foot brake cylinder piston and check free travel **A**.

Guideline

Free travel at foot brake lever	3 ... 5 mm (0.12 ... 0.2 in)
---------------------------------	------------------------------



Info

You will know that contact has been made with the foot brake cylinder piston when there is increased resistance when you activate the foot brake lever.

- » If the free travel does not meet specifications:
 - Adjust the basic position of the foot brake lever.  (📖 p. 137)

12.9 Adjusting the basic position of the foot brake lever



Warning

Danger of accidents The brake system fails in the event of overheating.

If there is no free travel on the foot brake lever, pressure builds up in the brake system on the rear brake.

- Set the free travel on the foot brake lever in accordance with the specification.

12 BRAKE SYSTEM

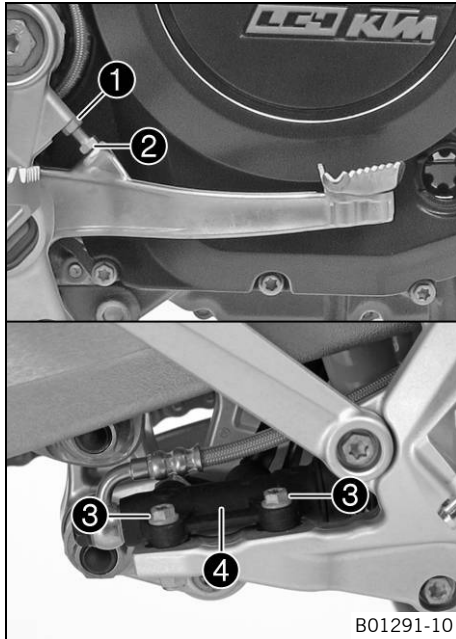

- Loosen fittings ③ on foot brake cylinder ④.
- To adjust the basic position of the foot brake lever individually, loosen nut ① and turn screw ② accordingly.

i Info

The range of adjustment is limited. The screw must be screwed into the footrest bracket by at least four turns.

- Position foot brake cylinder ④ so that the foot brake lever has the necessary free travel.
- Mount and tighten fittings ③.

Guideline

Screw connection, foot brake cylinder	M6	10 Nm (7.4 lbf ft)
--	----	--------------------

- Check the free travel of the foot brake lever. (📖 p. 136)
- Tighten nut ①.

12.10 Checking rear brake fluid level



Warning

Danger of accidents An insufficient brake fluid level will cause the brake system to fail.

If the brake fluid level drops below the **MIN** marking, the brake system is leaking or the brake linings are worn down.

- Check the brake system and do not continue riding until the problem is eliminated. (Your authorized KTM workshop will be glad to help.)



Warning

Danger of accidents Old brake fluid reduces the braking effect.

- Make sure that brake fluid for the front and rear brake is changed in accordance with the service schedule. (Your authorized KTM workshop will be glad to help.)

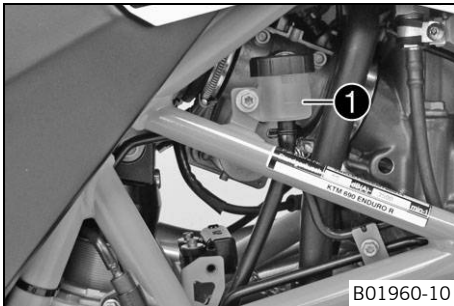

- Stand the vehicle upright.
- Check the brake fluid level in the brake fluid reservoir.
 - » If the fluid level reaches the **MIN** marking ❶:
 - Add rear brake fluid. 🛠️ (📖 p. 140)



12.11 Adding rear brake fluid



Warning

Danger of accidents An insufficient brake fluid level will cause the brake system to fail.

If the brake fluid level drops below the **MIN** marking, the brake system is leaking or the brake linings are worn down.

- Check the brake system and do not continue riding until the problem is eliminated. (Your authorized KTM workshop will be glad to help.)



Warning

Skin irritation Brake fluid causes skin irritation.

- Keep brake fluid out of the reach of children.
- Wear suitable protective clothing and safety glasses.
- Do not allow brake fluid to come into contact with the skin, the eyes or clothing.
- Consult a doctor immediately if brake fluid has been swallowed.
- Rinse the affected area with plenty of water in the event of contact with the skin.
- Rinse eyes thoroughly with water immediately and consult a doctor if brake fluid comes into contact with the eyes.
- If brake fluid spills on to your clothing, change the clothing.

**Warning**

Danger of accidents Old brake fluid reduces the braking effect.

- Make sure that brake fluid for the front and rear brake is changed in accordance with the service schedule. (Your authorized KTM workshop will be glad to help.)

**Warning**

Environmental hazard Hazardous substances cause environmental damage.

- Dispose of oils, grease, filters, fuel, cleaning agents, brake fluid, etc., correctly and in compliance with the applicable regulations.

**Info**

Never use DOT 5 brake fluid! It is silicone-based and purple in color. Oil seals and brake lines are not designed for DOT 5 brake fluid.

Avoid contact between brake fluid and painted parts. Brake fluid attacks paint!

Use only clean brake fluid from a sealed container.

Preparatory work

- Check the rear brake linings. (📖 p. 142)

12 BRAKE SYSTEM

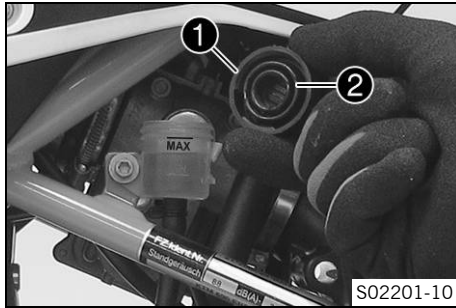

Main work

- Stand the vehicle upright.
- Remove screw cap ① with the washer and membrane ②.
- Add brake fluid to the **MAX** mark.

Brake fluid DOT 4 / DOT 5.1 (📖 p. 257)

- Mount the screw cap with the washer and membrane.



Info

Clean up overflowed or spilt brake fluid immediately with water.

12.12 Checking the rear brake linings



Warning

Danger of accidents Worn-out brake linings reduce the braking effect.

- Ensure that worn-out brake linings are replaced immediately. (Your authorized KTM workshop will be glad to help.)



Warning

Danger of accidents Damaged brake discs reduce the braking effect.

If the brake linings are not changed in time, the brake lining carriers grind against the brake disc. As a consequence, the braking effect is greatly reduced and the brake discs are destroyed.

- Check the brake linings regularly.

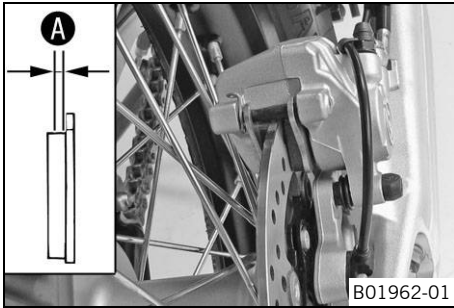

- Check the brake linings for minimum thickness **A**.

Minimum thickness A	$\geq 1 \text{ mm } (\geq 0.04 \text{ in})$
----------------------------	---

- » If the minimum thickness is less than specified:
 - Change the rear brake linings. 🛠️ (📖 p. 143)
- Check the brake linings for damage and cracking.
 - » If there is wear or tearing:
 - Change the rear brake linings. 🛠️ (📖 p. 143)

12.13 Changing the rear brake linings 🛠️



Warning

Danger of accidents Incorrect maintenance will cause the brake system to fail.

- Ensure that service work and repairs are performed professionally. (Your authorized KTM workshop will be glad to help.)



Warning

Skin irritation Brake fluid causes skin irritation.

- Keep brake fluid out of the reach of children.
- Wear suitable protective clothing and safety glasses.
- Do not allow brake fluid to come into contact with the skin, the eyes or clothing.
- Consult a doctor immediately if brake fluid has been swallowed.
- Rinse the affected area with plenty of water in the event of contact with the skin.
- Rinse eyes thoroughly with water immediately and consult a doctor if brake fluid comes into contact with the eyes.
- If brake fluid spills on to your clothing, change the clothing.



Warning

Danger of accidents Old brake fluid reduces the braking effect.

- Make sure that brake fluid for the front and rear brake is changed in accordance with the service schedule. (Your authorized KTM workshop will be glad to help.)



Warning

Danger of accidents Oil or grease on the brake discs reduces the braking effect.

- Always keep the brake discs free of oil and grease.
- Clean the brake discs with brake cleaner when necessary.

**Warning**

Danger of accidents Brake linings which have not been approved alter the braking efficiency.

Not all brake linings are tested and approved for KTM motorcycles. The structure and friction coefficient of the brake linings, and thus their brake power, may vary greatly from that of original brake linings. If brake linings are used that differ from the original equipment, compliance with the original homologation is not guaranteed. In this case, the vehicle no longer corresponds to its condition at delivery and the warranty shall be void.

- Only use brake linings approved and recommended by KTM.

**Warning**

Environmental hazard Hazardous substances cause environmental damage.

- Dispose of oils, grease, filters, fuel, cleaning agents, brake fluid, etc., correctly and in compliance with the applicable regulations.

**Info**

Never use DOT 5 brake fluid! It is silicone-based and purple in color. Oil seals and brake lines are not designed for DOT 5 brake fluid.

Avoid contact between brake fluid and painted parts. Brake fluid attacks paint!

Use only clean brake fluid from a sealed container.

12 BRAKE SYSTEM

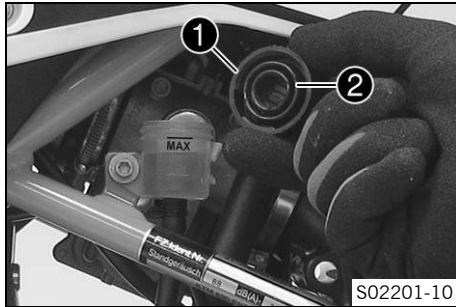

- Stand the vehicle upright.
- Remove screw cap 1 with membrane 2.
- Press the brake caliper by hand onto the brake disc in order to retract the brake piston. Ensure that brake fluid does not flow out of the brake fluid reservoir, extracting it by suction if it does.



Info

Make sure when pushing back the brake piston that you do not press the brake caliper against the spokes.

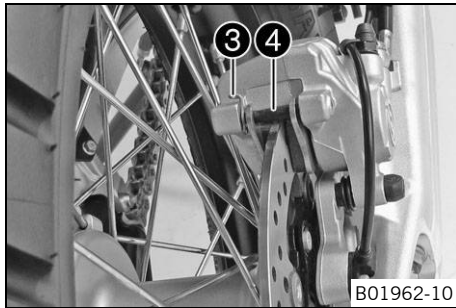

- Remove cotter pin 3, remove pin 4 toward the left by striking it, and remove the brake linings.
- Clean brake caliper and brake caliper support.

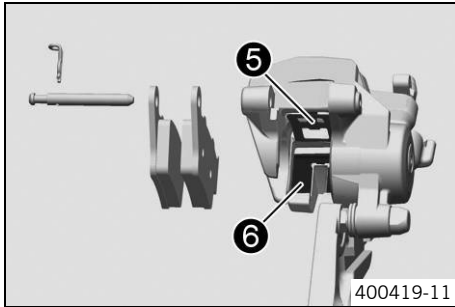

- Check that leaf spring **5** in the brake caliper and sliding plate **6** in the brake caliper support are seated correctly.
- Insert the new brake linings, insert the pin, and mount the cotter pin.



Info

Always change the brake linings in pairs.

- Operate the foot brake lever repeatedly until the brake linings are in contact with the brake disc and there is a pressure point.
- Adjust the brake fluid level to the **MAX** mark.

Brake fluid DOT 4 / DOT 5.1 (📖 p. 257)

- Mount the screw cap with the membrane.



Info

Clean up overflowed or spilt brake fluid immediately with water.



13.1 Removing the front wheel

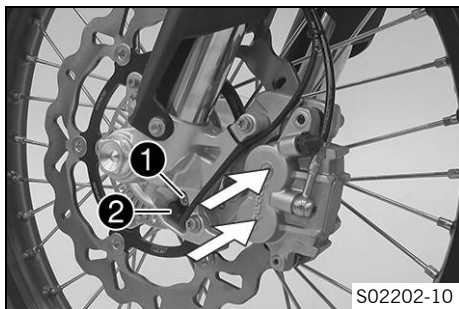

Preparatory work

- Raise the motorcycle with a lift stand. (📖 p. 95)

Main work

- Press the brake caliper onto the brake disc by hand in order to push back the brake pistons.

i Info

Make sure when pushing back the brake pistons that you do not press the brake caliper against the spokes.

- Remove screw **1** and pull wheel speed sensor **2** out of the hole.
- Loosen screw **3** by several rotations.
- Loosen screws **4**.
- Press on screw **3** to push the wheel spindle out of the axle clamp.
- Remove screw **3**.

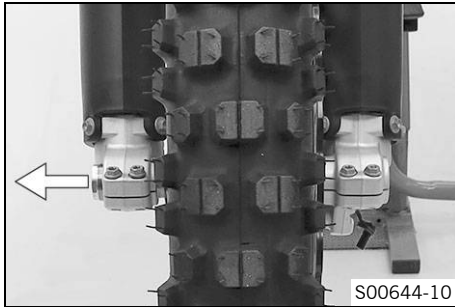

Warning

Danger of accidents Damaged brake discs reduce the braking effect.

- Always lay the wheel down in such a way that the brake disc is not damaged.

- Holding the front wheel, withdraw the wheel spindle. Take the front wheel out of the fork.



Info

Do not pull the hand brake lever when the front wheel is removed.

- Remove spacers **5**.

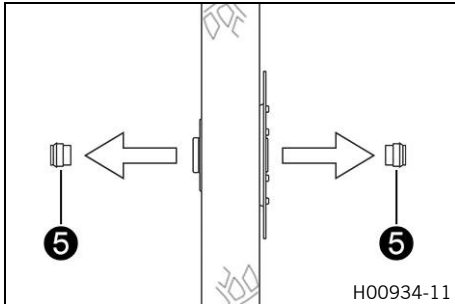

13.2 Installing the front wheel ↩



Warning

Danger of accidents Oil or grease on the brake discs reduces the braking effect.

- Always keep the brake discs free of oil and grease.
- Clean the brake discs with brake cleaner when necessary.

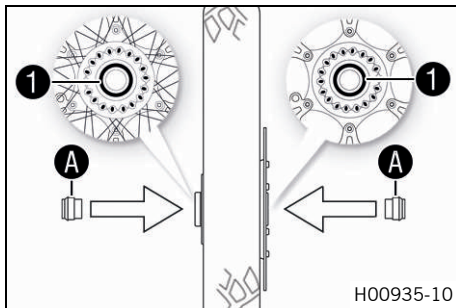

- Check the wheel bearing for damage and wear.
 - » If the wheel bearing is damaged or worn:
 - Replace the wheel bearing. ↩
- Clean and grease shaft seal rings 1 and contact surface A of the spacers.

Long-life grease (📖 p. 261)

- Insert the spacers.

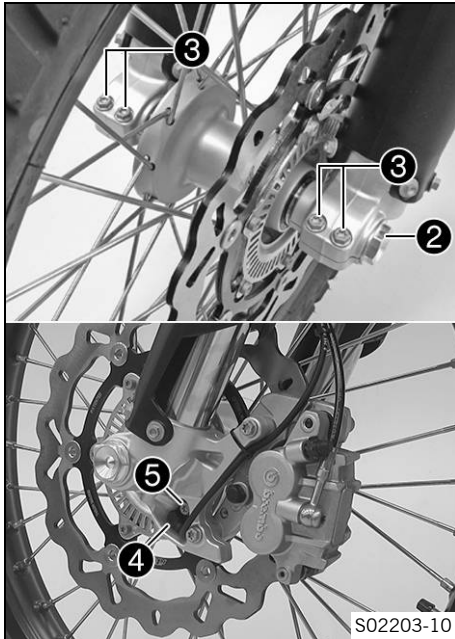

- Clean and grease the wheel spindle.

Long-life grease (📖 p. 261)

- Jack up the front wheel into the fork, position it, and insert the wheel spindle.
 - ✓ The brake linings are correctly positioned.
- Mount and tighten screw ②.

Guideline

Screw, front wheel spindle	M24x1.5	45 Nm (33.2 lbf ft)
----------------------------	---------	---------------------

- Operate the hand brake lever several times until the brake linings are seated correctly against the brake disc.
- Remove the motorcycle from the lift stand. (📖 p. 95)
- Operate the front brake and compress the fork a few times firmly.
 - ✓ The fork legs straighten.
- Tighten screws ③.

Guideline

Screw, fork stub	M8	15 Nm (11.1 lbf ft)
------------------	----	---------------------

- Position wheel speed sensor ④ in the drill hole. Mount and tighten screw ⑤.

Guideline

Screw, wheel speed sensor	M6	6 Nm (4.4 lbf ft)
---------------------------	----	-------------------

13.3 Removing the rear wheel ↴

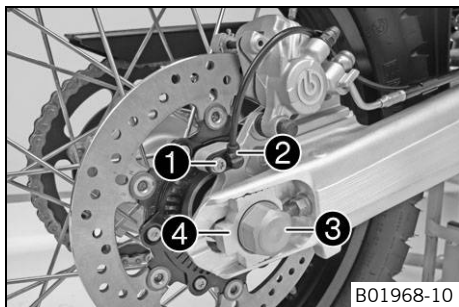

Preparatory work

- Raise the motorcycle with a lift stand. (📖 p. 95)

Main work

- Remove screw ❶ and pull wheel speed sensor ❷ out of the hole.
- Press the brake caliper onto the brake disc by hand in order to push back the brake piston.
- Remove nut ❸. Remove chain adjuster ❹.



Info

Cover the components to protect them against damage.

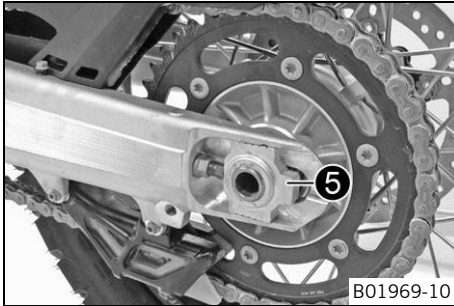

- Holding the rear wheel, withdraw wheel spindle ⑤.



- Push the rear wheel forward as far as possible and take the chain off the rear sprocket.



Warning

Danger of accidents Damaged brake discs reduce the braking effect.

- Always lay the wheel down in such a way that the brake disc is not damaged.

- Take the rear wheel out of the swingarm.



Info

Do not operate the foot brake when the rear wheel is removed.



13.4 Installing the rear wheel 🛠️



Warning

Danger of accidents Oil or grease on the brake discs reduces the braking effect.

- Always keep the brake discs free of oil and grease.
- Clean the brake discs with brake cleaner when necessary.



Warning

Danger of accidents There is no braking effect to start with at the rear brake after installing the rear wheel.

- Actuate the foot brake several times before going on a ride until you can feel a firm pressure point.

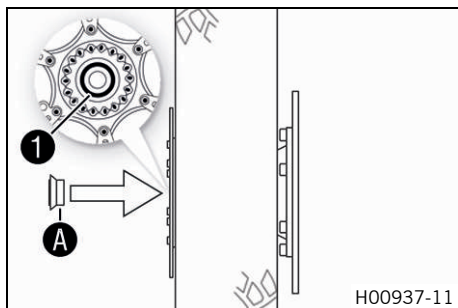

Main work

- Check the rear hub rubber dampers. 🛠️ (📖 p. 156)
- Check the wheel bearing for damage and wear.
 - » If the wheel bearing is damaged or worn:
 - Replace the wheel bearing. 🛠️
- Remove spacer.
- Clean and grease shaft seal ring (1) and contact surface (A) of the spacer.

Long-life grease (📖 p. 261)
- Insert the spacer.

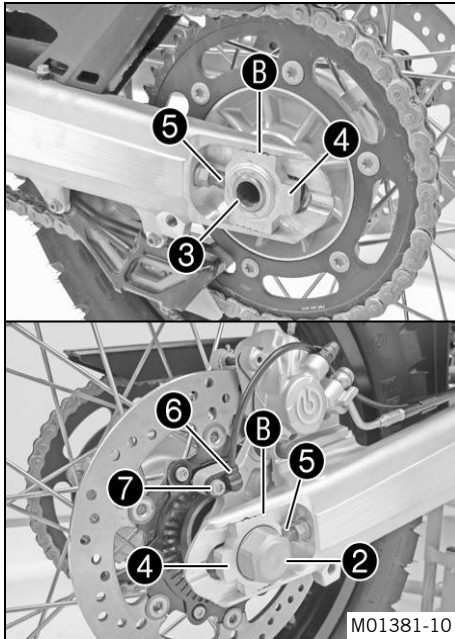

M01381-10

- Clean and grease the thread of the wheel spindle and nut **2**.

Long-life grease (📖 p. 261)

- Clean and grease the wheel spindle.

Long-life grease (📖 p. 261)

- Mount the rubber damper and rear sprocket carrier in the rear wheel.
- Position the rear wheel.
 - ✓ The brake linings are correctly positioned.
- Push the rear wheel forward as far as possible and lay the chain on the rear sprocket.
- Mount wheel spindle **3** and chain adjuster **4**. Mount nut **2**, but do not tighten it yet.
- Make sure that chain adjusters **4** are fitted correctly on adjusting screws **5**.
- Make sure that the markings on the left and right chain adjusters are in the same position relative to reference marks **B**. The rear wheel is then correctly aligned.
- Tighten nut **2**.

Guideline

Nut, rear wheel spindle	M25x1.5	90 Nm (66.4 lbf ft)
-------------------------	---------	---------------------

- Position wheel speed sensor ⑥ in the drill hole. Mount and tighten screw ⑦.

Guideline

Screw, wheel speed sensor	M6	6 Nm (4.4 lbf ft)
---------------------------	----	-------------------

- Operate the foot brake lever repeatedly until the brake linings are in contact with the brake disc and there is a pressure point.

Finishing work

- Remove the motorcycle from the lift stand. (📖 p. 95)
- Check the chain tension. (📖 p. 107)

13.5 Checking the rear hub rubber dampers 🛠️

i Info

The engine power is transmitted from the rear sprocket to the rear wheel via 6 rubber dampers. They eventually wear out during operation. If the rubber dampers are not changed in time, the rear sprocket carrier and the rear hub become damaged.

Preparatory work

- Raise the motorcycle with a lift stand. (📖 p. 95)
- Remove the rear wheel. 🛠️ (📖 p. 152)

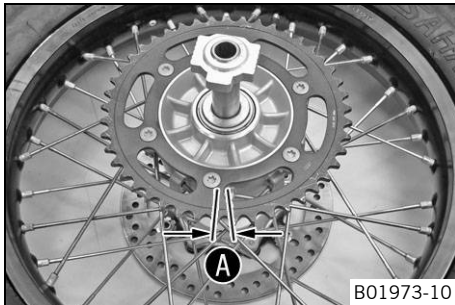
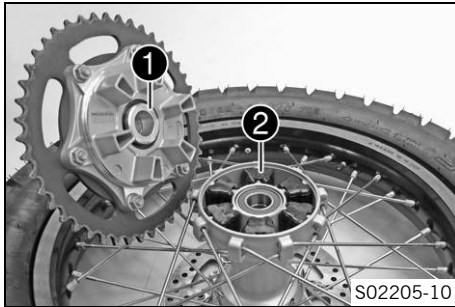

Main work

- Check bearing ①.
 - » If the bearing is damaged or worn:
 - Replace the bearings. 🛠️
- Check rubber dampers ② of the rear hub for damage and wear.
 - » If the rubber dampers of the rear hub are damaged or worn:
 - Change all rubber dampers in the rear hub.
- Lay the rear wheel on a workbench with the rear sprocket facing upwards and insert the wheel spindle in the hub.
- To check play A, hold the rear wheel tight and try to turn the rear sprocket with your hand.



Info

Measure the play on the outside of the rear sprocket.

Play in rubber dampers, rear wheel	$\leq 5 \text{ mm } (\leq 0.2 \text{ in})$
------------------------------------	--

- » If clearance A larger than the specified value:
 - Change all rubber dampers in the rear hub.

Finishing work

- Install the rear wheel. 🛠️ (📖 p. 154)
- Remove the motorcycle from the lift stand. (📖 p. 95)

- Check the chain tension. (📖 p. 107)

13.6 Checking the tire condition



Warning

Danger of accidents If a tire bursts while riding, the vehicle becomes uncontrollable.

- Ensure that damaged or worn tires are replaced immediately. (Your authorized KTM workshop will be glad to help.)



Warning

Danger of crashing Different tire tread patterns on the front and rear wheel impair the handling characteristic.

Different tire tread patterns can make the vehicle significantly more difficult to control.

- Make sure that only tires with a similar tire tread pattern are fitted to the front and rear wheel.



Warning

Danger of accidents Non-approved or non-recommended tires and wheels impact the handling characteristic.

- Only use tires/wheels approved by KTM with the corresponding speed index.



Warning

Danger of accidents New tires have reduced road grip.

The contact surface on new tires is not yet roughened.

- Run in new tires with moderate riding at alternating angles.
Running-in phase 200 km (124 mi)



Info

The type, condition, and air pressure of the tires all have a major impact on the handling of the motorcycle.

Worn tires have a negative effect on handling characteristics, especially on wet surfaces.

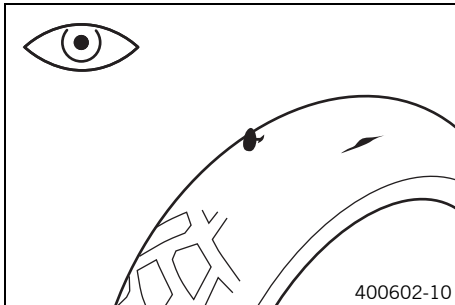

- Check the front and rear tires for cuts, run-in objects, and other damage.
 - » If the tires have cuts, run-in objects, or other damage:
 - Change the tires. 🛠️
- Check the tread depth.



Info

Adhere to the legally required minimum tread depth.

Minimum tread depth	$\geq 2 \text{ mm } (\geq 0.08 \text{ in})$
---------------------	---

- » If the tread depth is less than the minimum tread depth:
 - Change the tires. 🛠️

13 WHEELS, TIRES

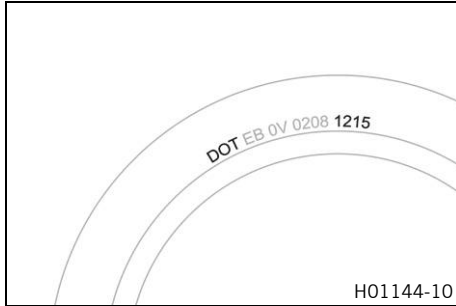

- Check the tire age.



Info

The tire date of manufacture is usually contained in the tire label and is indicated by the last four digits of the **DOT** number. The first two digits indicate the week of manufacture and the last two digits the year of manufacture.

KTM recommends that the tires be changed after 5 years at the latest, regardless of the actual state of wear.

- » If the tires are more than 5 years old:
 - Change the tires. 🛠️

13.7 Checking the tire air pressure



Info

Low tire air pressure leads to abnormal wear and overheating of the tire.

Correct tire air pressure ensures optimal riding comfort and maximum tire service life.

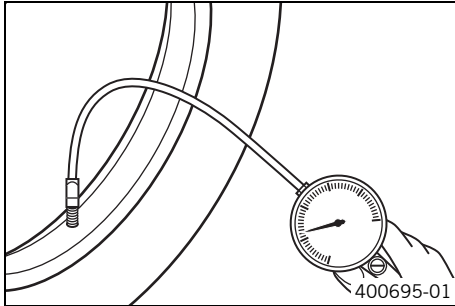

- Remove the protection cap.
- Check the tire air pressure when the tires are cold.

Tire air pressure, offroad, single rider	
front	1.5 bar (22 psi)
rear	1.5 bar (22 psi)

Tire air pressure, road, solo	
front	1.8 bar (26 psi)
rear	1.8 bar (26 psi)

Tire air pressure with passenger / fully loaded	
front	2.2 bar (32 psi)
rear	2.2 bar (32 psi)

- » If the tire pressure does not meet specifications:
 - Correct the tire pressure.
- Mount the protection cover.



13.8 Checking the spoke tension



Warning

Danger of accidents Incorrectly tensioned spokes impair the handling characteristic and result in secondary damage.

The spokes break due to being overloaded if they are too tightly tensioned. If the tension in the spokes is too low, then lateral and radial run-out will form in the wheel. Other spokes will become looser as a result.

- Check spoke tension regularly, and in particular on a new vehicle. (Your authorized KTM workshop will be glad to help.)



Info

A loose spoke causes wheel imbalance and rapidly leads to more loose spokes. If the spokes are too tight, they can break due to local overload. Check the spoke tension regularly, especially on a new motorcycle.

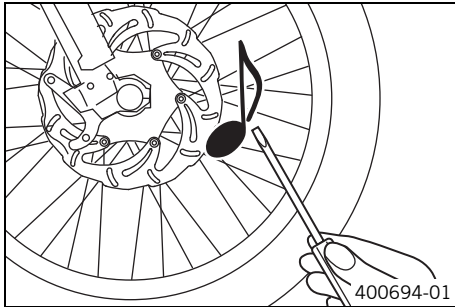

- Briefly strike each spoke with a screwdriver blade.



Info

The frequency of the tone is a function of the spoke length and spoke diameter. If you hear different tone frequencies from individual spokes of the same length and thickness, this is an indication of different spoke tensions.

You should hear a high note.

- » If the spoke tensions differ:
 - Correct the spoke tension. 🛠️



14.1 Removing the battery ↩



Warning

Risk of injury Battery acid and battery gases cause serious chemical burns.

- Keep batteries out of the reach of children.
- Wear suitable protective clothing and safety glasses.
- Avoid contact with battery acid and battery gases.
- Keep sparks or open flames away from the battery.
- Only charge batteries in well-ventilated rooms.
- Rinse the affected area immediately with plenty of water in the event of contact with the skin.
- Rinse eyes with water for at least 15 minutes and consult a doctor immediately if battery acid and battery gases get into the eyes.

Preparatory work

- Switch off the ignition by turning the ignition key to position **OFF** ☒.
- Remove the seat. (📖 p. 102)

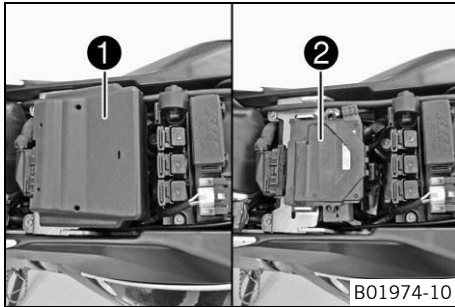
**Main work**

- Remove battery cover ①.
- Pull engine electronics control unit ② off of the holder and set it to one side.

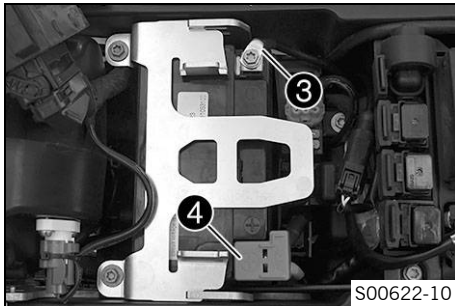

- Disconnect negative cable ③ from the battery.
- Take off positive terminal cover ④.

14 ELECTRICAL SYSTEM

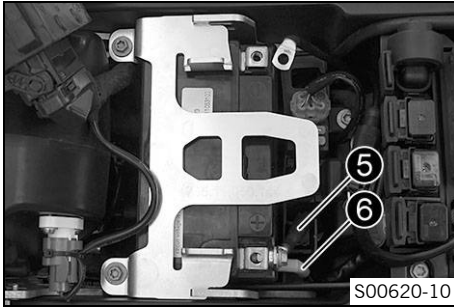

- Disconnect ABS connection cable 5 and positive cable 6 from the battery.

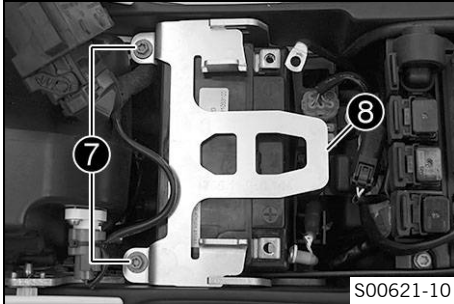

- Remove screws 7.
- Pull retaining bracket 8 of the battery forward and remove it.
- Lift the battery up and out.



Info

Never operate the motorcycle with a discharged battery or without a battery. In both cases, electrical components and safety devices can be damaged. The vehicle will therefore no longer be roadworthy.

14.2 Installing the battery ↗

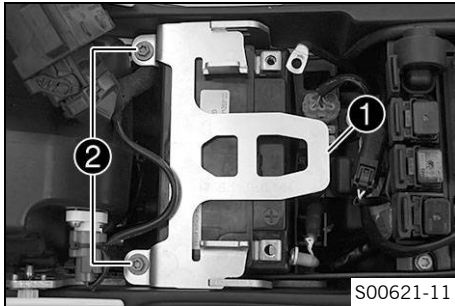

Main work

- Insert the battery into the battery compartment with the terminals facing rearward.

Battery (YTZ10S) (🗨️ p. 246)

- Position retaining bracket **1** and mount and tighten screws **2**.

Guideline

Remaining screws, chassis	M6	10 Nm (7.4 lbf ft)
---------------------------	----	--------------------

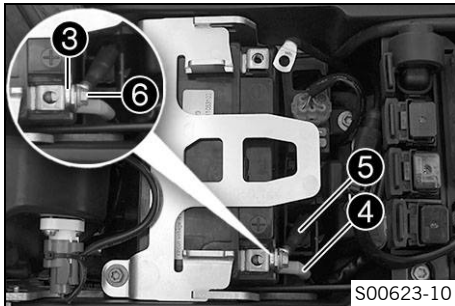

- Position washer **3**, positive cable **4**, and ABS connection cable **5**.
- Mount and tighten screw **6**.

Guideline

Screw, battery terminal	M6	4.5 Nm (3.32 lbf ft)
-------------------------	----	----------------------

14 ELECTRICAL SYSTEM

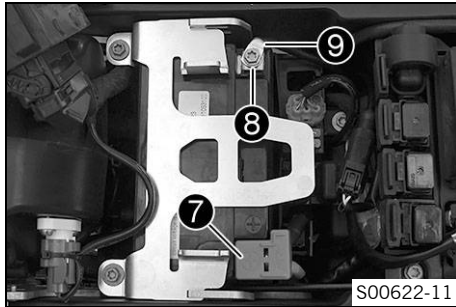

- Position positive terminal cover 7.
- Position washer 8 and negative cable 9, and mount and tighten the screw.

Guideline

Screw, battery terminal	M6	4.5 Nm (3.32 lbf ft)
-------------------------	----	-------------------------

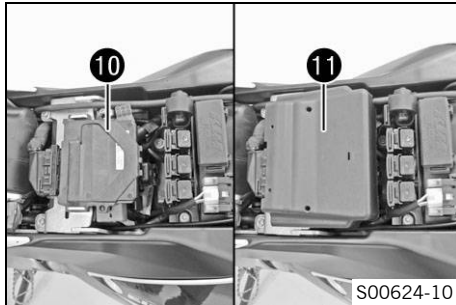

- Position the engine electronics control unit 10.
- Mount battery cover 11.

Finishing work

- Mount the seat. (📖 p. 102)
- Set the clock. (📖 p. 38)

14.3 Recharging the battery ↴



Warning

Risk of injury Battery acid and battery gases cause serious chemical burns.

- Keep batteries out of the reach of children.
- Wear suitable protective clothing and safety glasses.
- Avoid contact with battery acid and battery gases.
- Keep sparks or open flames away from the battery.
- Only charge batteries in well-ventilated rooms.
- Rinse the affected area immediately with plenty of water in the event of contact with the skin.
- Rinse eyes with water for at least 15 minutes and consult a doctor immediately if battery acid and battery gases get into the eyes.



Warning

Environmental hazard Batteries contain environmentally-hazardous materials.

- Do not dispose of batteries as household waste.
- Dispose of batteries at a collection point for used batteries.



Warning

Environmental hazard Hazardous substances cause environmental damage.

- Dispose of oils, grease, filters, fuel, cleaning agents, brake fluid, etc., correctly and in compliance with the applicable regulations.

Info

Even when there is no load on the battery, it still loses power steadily.

The charging level and the method of charging are very important for the service life of the battery.

Rapid recharging with a high charging current shortens the battery's service life.





If the charging current, charging voltage and charging time are exceeded, electrolyte escapes through the safety valves. This reduces the battery capacity.

If the battery is depleted from starting the vehicle repeatedly, the battery must be charged immediately.

If the battery is left in a discharged state for an extended period, it will become over-discharged and sulfate, destroying the battery.

The battery is maintenance-free, which means that the acid level does not need to be checked.

Preparatory work

- Switch off the ignition by turning the ignition key to position **OFF** .
- Remove the seat.  p. 102)
- Remove the battery.   p. 164)



Main work

- Connect the battery charger to the battery. Switch on the battery charger.

Battery charger (58429074000)

You can also use the battery charger to test rest potential and start potential of the battery, and to test the alternator. With this device, you cannot overcharge the battery.



Info

Never remove lid **1**.

Charge the battery with a maximum of 10% of the capacity specified on the battery housing **2**.

- Switch off the battery charger after charging and disconnect from the battery.

Guideline

The charge current, charge voltage and charge time must not be exceeded.

Charge the battery regularly when the motorcycle is not in use	3 months
--	----------

Finishing work

- Install the battery. 🛠️ (📖 p. 167)
- Mount the seat. (📖 p. 102)

- Set the clock. (📖 p. 38)

14.4 Changing the main fuse



Warning

Fire hazard Incorrect fuses overload the electrical system.

- Only use fuses with the required ampere value.
- Do not bypass or repair fuses.



Info

The main fuse protects all power consumers of the vehicle. It is in the housing of the starter relay next to the battery.

Preparatory work

- Switch off the ignition by turning the ignition key to position **OFF** ☒.
- Remove the seat. (📖 p. 102)

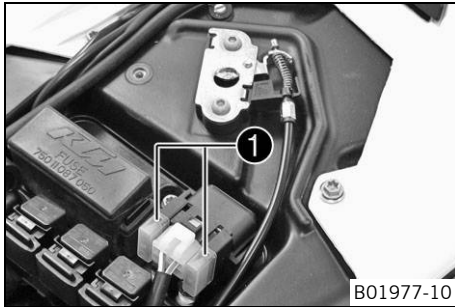

Main work

- Take off protection caps ①.

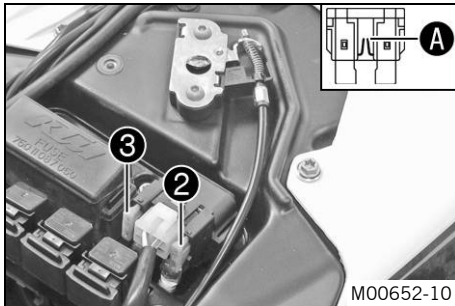

- Remove a defective main fuse ② with needle nose pliers.

i Info

A defective fuse is indicated by a burned-out fuse wire **A**.

A spare fuse ③ is located in the starter relay.

- Install a new main fuse.

Fuse (58011109130) (📖 p. 246)

i Info

Insert a new spare fuse into the starter relay to have it available when needed.

- Check that the electrical equipment is functioning properly.
- Mount the protection caps.

Finishing work

- Mount the seat. (📖 p. 102)
- Set the clock. (📖 p. 38)

14.5 Changing the ABS fuses



Warning

Fire hazard Incorrect fuses overload the electrical system.

- Only use fuses with the required ampere value.
- Do not bypass or repair fuses.



Info

Two fuses for the ABS are located under the seat. These fuses protect the return pump and the hydraulic unit of the ABS. The third fuse, which protects the ABS control unit, is located in the fuse box.

Preparatory work

- Switch off the ignition by turning the ignition key to position **OFF** ☒.
- Remove the seat. (📖 p. 102)
- Remove the battery cover.
- Pull the engine electronics control unit off of the holder and set it to one side.

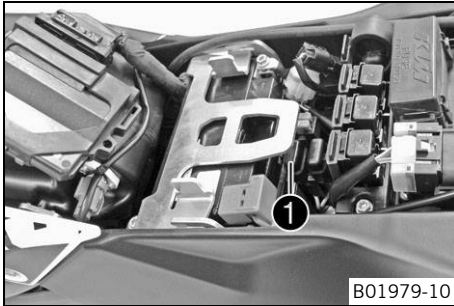

To change the fuse of the ABS hydraulic unit:

- Take off protection cap ❶ and remove the fuse.
- Insert a new fuse.

Fuse (58011109115) (📖 p. 246)

- Mount the protection cap.

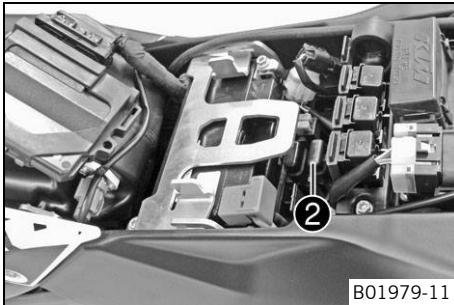

To change the fuse of the ABS return pump:

- Take off protection cap ❷ and remove the fuse.
- Insert a new fuse.

Fuse (58011109125) (📖 p. 246)

- Mount the protection cap.

Finishing work

- Position the engine electronics control unit.
- Mount the battery cover.
- Mount the seat. (📖 p. 102)



14.6 Changing the fuses of individual power consumers



Info

The fuse box containing the fuses of individual power consumers is located under the seat.

Preparatory work

- Switch off the ignition by turning the ignition key to position **OFF** ☒.
- Remove the seat. (📖 p. 102)

Main work

- Open fuse box cover **1**.

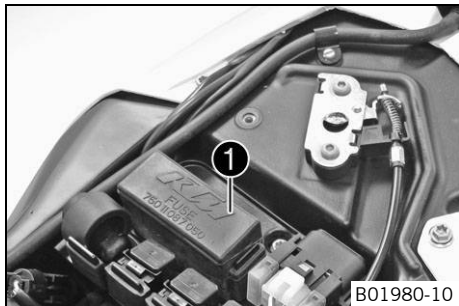

B01980-10

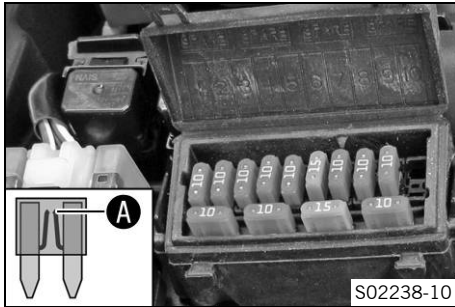

- Remove the faulty fuse.

Guideline

Fuse 1 - 10 A - ignition
Fuse 2 - 10 A - ignition, combination instrument, engine electronics control unit, lambda sensor
Fuse 3 - 10 A - fuel pump
Fuse 4 - 10 A - radiator fan
Fuse 5 - 10 A - horn, brake light, turn signal
Fuse 6 - 15 A - high beam, low beam, parking light, tail light, license plate lamp
Fuse 7 - 10 A - for auxiliary equipment (permanent positive)
Fuse 8 - 10 A - for auxiliary equipment (accessories connected with ignition switch)
Fuse 9 - 10 A - ABS
Fuse 10 - not assigned
Fuse SPARE - 10 A/15 A - spare fuses



Info

You can recognize a faulty fuse by a burned-out fuse wire **A**.



Warning

Fire hazard Incorrect fuses overload the electrical system.

- Only use fuses with the required ampere value.
- Do not bypass or repair fuses.

- Use spare fuses with the correct rating only.

Fuse (75011088010) (📖 p. 246)

Fuse (75011088015) (📖 p. 246)



Tip

Replace the spare fuse in the fuse box so that it is available if needed.

- Check that the power consumer is functioning properly.
- Close the fuse box cover.

Finishing work

- Mount the seat. (📖 p. 102)

14.7 Removing the headlight mask with the headlight

- Switch off the ignition by turning the ignition key to position **OFF** ☒.
- Cover the fender with a cloth to protect it from damage.
- Remove screws **1** on both sides.
- Tip the headlight mask forward.

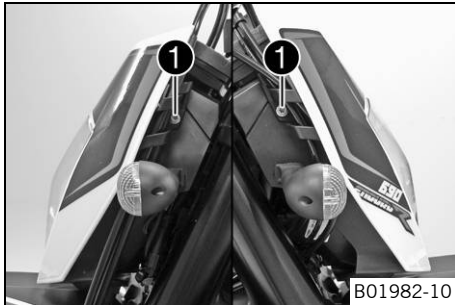

- Disconnect plug-in connectors **2** for the turn signals and **3** for the headlight.
- Take off the headlight mask.

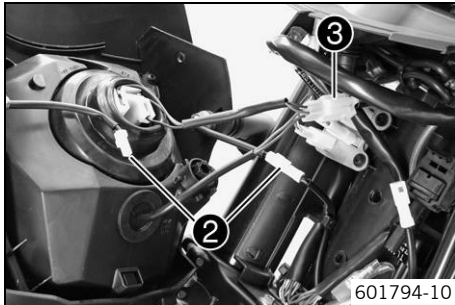

14.8 Installing the headlight mask with the headlight

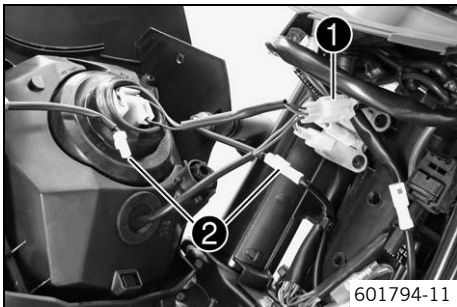

Main work

- Connect plug-in connectors **1** of the headlight and **2** of the turn signals.
- Check that the lighting is functioning properly.

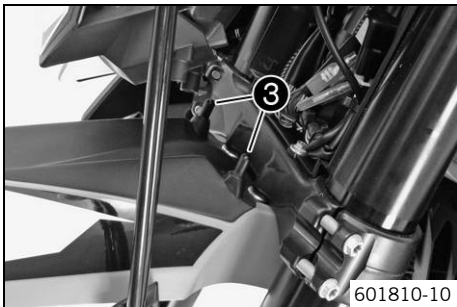

- Remove the cloth from the fender and position the headlight mask.
 - ✓ Holding lugs **3** reach into the headlight mask.

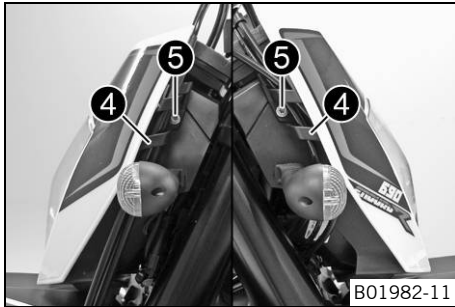

- Position line guides ④. Mount and tighten screws ⑤.

Guideline

Screw, headlight mask	M5	5 Nm (3.7 lbf ft)
-----------------------	----	-------------------

Finishing work

- Check the headlight setting. (📖 p. 186)



14.9 Changing the headlight bulb

Note

Damage to reflector Grease on the reflector reduces the brightness.

Grease on the bulb will evaporate due to the heat and be deposited on the reflector.

- Clean and degrease the bulbs before mounting.
- Do not touch the bulbs with your bare hands.

Preparatory work

- Remove the headlight mask with the headlight. (📖 p. 179)

14 ELECTRICAL SYSTEM

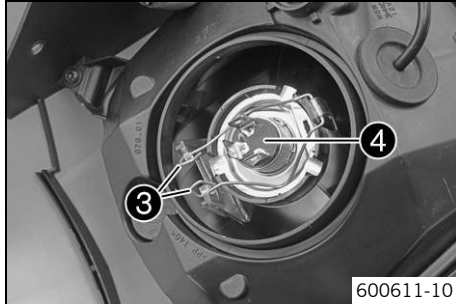
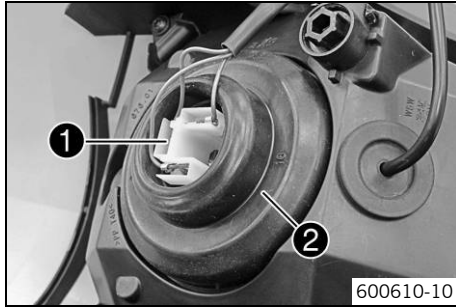

Main work

- Unplug connector ①.
- Take off protection cap ② of the headlight bulb.

- Detach spring bar ③.
- Remove headlight bulb ④.
- Insert a new headlight bulb into the headlight housing.

Headlight (H4 / socket P43t) (📖 p. 247)

- Fix the headlight bulb in the headlight using the spring bar.
- Mount the protection cap. Plug in the connector.

Finishing work

- Install the headlight mask with the headlight. (📖 p. 180)
- Check the headlight setting. (📖 p. 186)

14.10 Changing the parking light bulb

Note

Damage to reflector Grease on the reflector reduces the brightness.

Grease on the bulb will evaporate due to the heat and be deposited on the reflector.

- Clean and degrease the bulbs before mounting.
- Do not touch the bulbs with your bare hands.

Preparatory work

- Remove the headlight mask with the headlight. (📖 p. 179)

Main work

- Remove protection cap ❶.

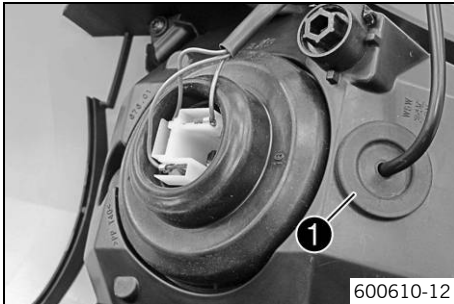

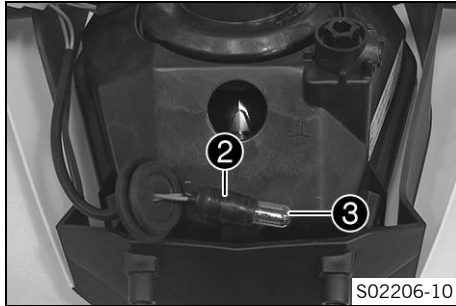

- Pull bulb socket ② out of the reflector.
- Pull parking light bulb ③ out of the bulb socket.
- Insert a new parking light bulb in the bulb socket.

Parking light (W5W / socket W2.1x9.5d) (📖 p. 247)

- Insert the bulb socket in the reflector.
- Insert the protection cap.

Finishing work

- Install the headlight mask with the headlight. (📖 p. 180)
- Check the headlight setting. (📖 p. 186)

14.11 Changing the turn signal bulb

Note

Damage to reflector Grease on the reflector reduces the brightness.

Grease on the bulb will evaporate due to the heat and be deposited on the reflector.

- Clean and degrease the bulbs before mounting.
- Do not touch the bulbs with your bare hands.

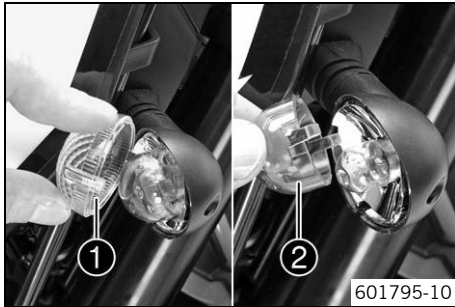

Main work

- Remove the screw on the rear of the turn signal housing.
- Tilt headlamp diffuser **1** forward carefully and take it off.
- Lightly squeeze orange cap **2** in the area of the holding lugs and take it off.
- Press the turn signal bulb lightly into the socket, turn it counterclockwise by about 30°, and take it out of the socket.



Info

Do not touch the reflector with your fingers, and keep it free from grease.

- Press the new turn signal bulb carefully into the socket and turn it clockwise until it stops.

Turn signal (R10W / socket BA15s) (📖 p. 247)

- Mount the orange cap.
- Position the diffuser.
- Insert the screw and first turn counterclockwise until it engages in the thread with a small jerk. Tighten the screw lightly.

Finishing work

- Check that the turn signal system is functioning properly.



14.12 Checking the headlight setting

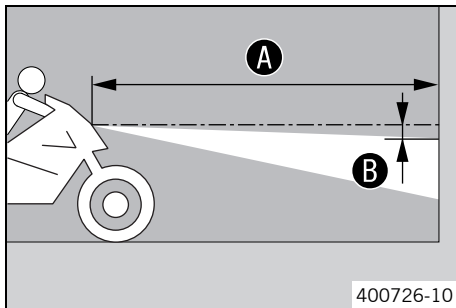

- Position the vehicle upright on a horizontal surface in front of a light wall and make a mark at the height of the center of the low beam headlight.

- Make another mark at a distance **B** under the first mark.

Guideline

Distance B	5 cm (2 in)
-------------------	-------------

- Position the vehicle vertically at a distance **A** away from the wall.

Guideline

Distance A	5 m (16 ft)
-------------------	-------------

- The rider, with luggage and passenger if applicable, now mounts the motorcycle.
- Switch on the low beam.
- Check the headlight setting.

The light-dark boundary must lie exactly on the lower mark when the motorcycle is ready to operate with the rider mounted along with any luggage and a passenger if applicable.

- » If the boundary between light and dark does not meet specifications:
 - Adjust the headlight range. (📖 p. 187)

14.13 Adjusting the headlight range



Preparatory work

- Check the headlight setting. (📖 p. 186)

Main work

- Turn adjusting screw ❶ to adjust the headlight range.

Guideline

The boundary between light and dark must be exactly on the lower mark for a motorcycle with rider (instructions on how to apply the mark: Checking the headlight setting).



Info

Turn clockwise to increase the headlight range; turn counterclockwise to reduce the headlight range. If you have a payload, you may have to correct the headlight range.



14 ELECTRICAL SYSTEM

14.14 Diagnostics connector

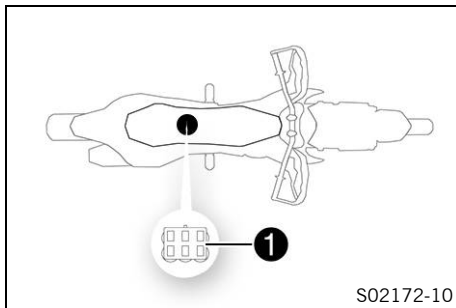

Diagnostics connector **1** is located under the engine control unit.

15.1 Cooling system

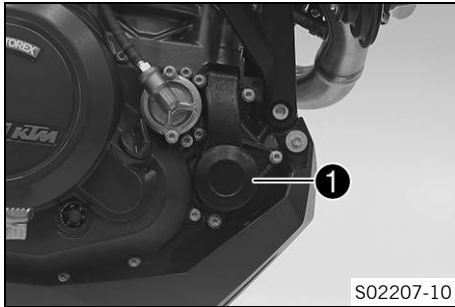

The water pump **1** in the engine forces the coolant to flow. The pressure in the cooling system resulting from heat is regulated by a valve in the radiator cap **2**. The heat expansion causes the surplus coolant to flow into the compensating tank **3**. When the temperature falls, this surplus coolant is sucked back into the cooling system. This permits the specified coolant temperature without causing any malfunctions.

125 °C (257 °F)

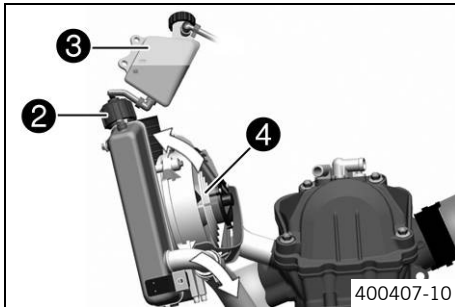

Cooling takes place by means of the air stream and a radiator fan **4**, which is controlled by a thermostitch. The lower the speed, the less the cooling effect. Dirty cooling fins also reduce the cooling effect.

15.2 Checking the antifreeze and coolant level



Warning

Danger of scalding During motorcycle operation, the coolant gets very hot and is under pressure.

- Do not open the radiator, the radiator hoses or other cooling system components if the engine or the cooling system are at operating temperature.
- Allow the cooling system and the engine to cool down before you open the radiator, the radiator hoses or other components of the cooling system.
- In the event of scalding, rinse the area affected immediately with lukewarm water.



Warning

Danger of poisoning Coolant is toxic and a health hazard.

- Keep coolant out of the reach of children.
- Do not allow coolant to come into contact with the skin, the eyes and clothing.
- Consult a doctor immediately if coolant is swallowed.
- Rinse the affected area immediately with plenty of water in the event of contact with the skin.
- Rinse eyes thoroughly with water and consult a doctor immediately if coolant gets into the eyes.
- Change clothing if coolant spills onto your clothing.

Condition

The engine is cold.



- Stand the motorcycle on its side stand on a horizontal surface.
- Remove the cover of compensating tank ❶.
- Check the antifreeze in the coolant.

-25 ... -45 °C (-13 ... -49 °F)

- » If the antifreeze in the coolant does not match the specified value:
 - Correct the antifreeze in the coolant.
- Check the coolant level in the compensating tank.

The coolant level must be within the range shown in the figure.

- » If the coolant level does not match the specified value:
 - Correct the coolant level.

Coolant (📖 p. 257)

- Mount the cover of the compensating tank.

15 COOLING SYSTEM

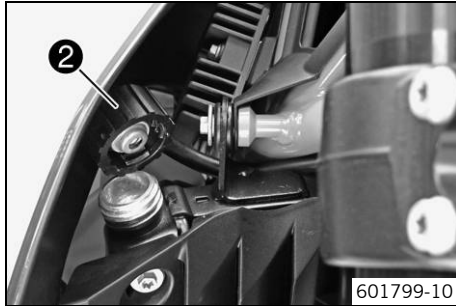

- Remove radiator cap ②.
- Check the antifreeze in the coolant.

-25 ... -45 °C (-13 ... -49 °F)

- » If the antifreeze in the coolant does not match the specified value:
 - Correct the antifreeze in the coolant.

- Check the coolant level in the radiator.

The radiator must be filled completely.

- » If the coolant level does not match the specified value:
 - Check the coolant level and the reason for the loss.

Coolant (📖 p. 257)

- Mount the radiator cap.

15.3 Checking the coolant level



Warning

Danger of scalding During motorcycle operation, the coolant gets very hot and is under pressure.

- Do not open the radiator, the radiator hoses or other cooling system components if the engine or the cooling system are at operating temperature.
- Allow the cooling system and the engine to cool down before you open the radiator, the radiator hoses or other components of the cooling system.
- In the event of scalding, rinse the area affected immediately with lukewarm water.



Warning

Danger of poisoning Coolant is toxic and a health hazard.

- Keep coolant out of the reach of children.
- Do not allow coolant to come into contact with the skin, the eyes and clothing.
- Consult a doctor immediately if coolant is swallowed.
- Rinse the affected area immediately with plenty of water in the event of contact with the skin.
- Rinse eyes thoroughly with water and consult a doctor immediately if coolant gets into the eyes.
- Change clothing if coolant spills onto your clothing.

Condition

The engine is cold.

15 COOLING SYSTEM



- Stand the motorcycle on its side stand on a horizontal surface.
- Check the coolant level in compensating tank ①.

The coolant level must be within the range shown in the figure.

- » If the coolant level does not match the specified value:
 - Correct the coolant level.

Coolant (📖 p. 257)

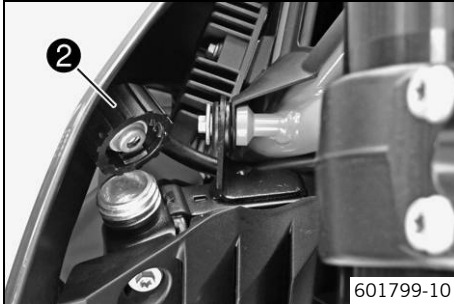

- Remove radiator cap ② and check the coolant level in the radiator.

The radiator must be filled completely.

- » If the coolant level does not match the specified value:
 - Check the coolant level and the reason for the loss.

Coolant (📖 p. 257)

- Mount the radiator cap.

15.4 Draining the coolant



Warning

Danger of scalding During motorcycle operation, the coolant gets very hot and is under pressure.

- Do not open the radiator, the radiator hoses or other cooling system components if the engine or the cooling system are at operating temperature.
- Allow the cooling system and the engine to cool down before you open the radiator, the radiator hoses or other components of the cooling system.
- In the event of scalding, rinse the area affected immediately with lukewarm water.



Warning

Danger of poisoning Coolant is toxic and a health hazard.

- Keep coolant out of the reach of children.
- Do not allow coolant to come into contact with the skin, the eyes and clothing.
- Consult a doctor immediately if coolant is swallowed.
- Rinse the affected area immediately with plenty of water in the event of contact with the skin.
- Rinse eyes thoroughly with water and consult a doctor immediately if coolant gets into the eyes.
- Change clothing if coolant spills onto your clothing.

Preparatory work

- Remove the engine guard. ( p. 120)

15 COOLING SYSTEM

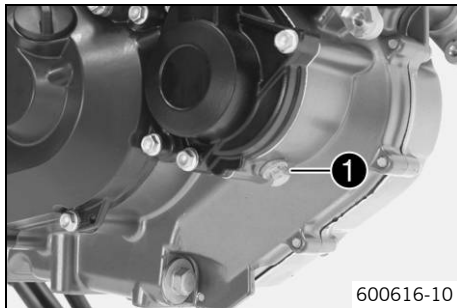

Main work

- Position the motorcycle upright.
- Place a suitable container under the engine.
- Remove screw ❶. Remove the radiator cap.
- Completely drain the coolant.
- Mount and tighten screw ❶ with a new seal ring.

Guideline

Plug, drain hole of water pump	M10x1	15 Nm (11.1 lbf ft)
--------------------------------	-------	---------------------

Finishing work

- Install the engine guard. (🔧 p. 121)

15.5 Filling/bleeding the cooling system



Warning

Danger of poisoning Coolant is toxic and a health hazard.

- Keep coolant out of the reach of children.
- Do not allow coolant to come into contact with the skin, the eyes and clothing.
- Consult a doctor immediately if coolant is swallowed.
- Rinse the affected area immediately with plenty of water in the event of contact with the skin.
- Rinse eyes thoroughly with water and consult a doctor immediately if coolant gets into the eyes.
- Change clothing if coolant spills onto your clothing.

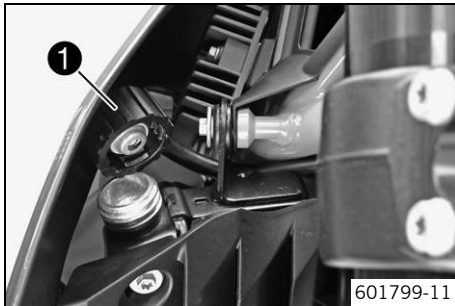

- Stand the motorcycle on its side stand on a horizontal surface.
- Remove radiator cap **1**.

15 COOLING SYSTEM

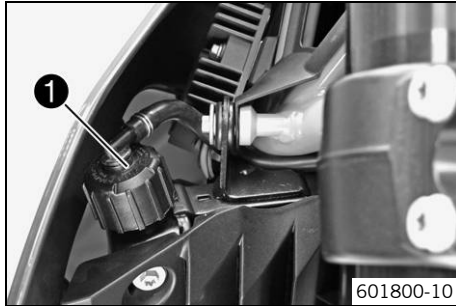

- Refill with coolant.

Coolant (🗨️ p. 257)

- Completely fill the radiator with coolant.
- Mount radiator cap ❶.

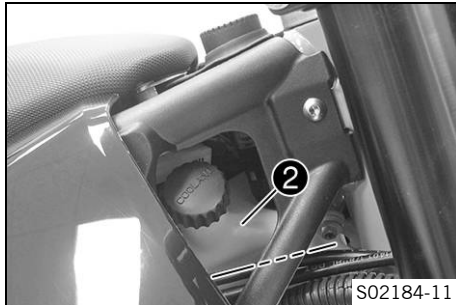

- Remove the cover of compensating tank ❷.
- Add coolant to the level shown in the figure.
- Mount the cover of the compensating tank.



Danger

Danger of poisoning Exhaust gases are toxic and inhaling them may result in unconsciousness and death.

- Always make sure there is sufficient ventilation when running the engine.
- Use an effective exhaust extraction system when starting or running the engine in an enclosed space.

- Start the engine and run it until the 5th bar of the temperature indicator lights up.
- Stop the engine and allow it to cool down.

- Check the coolant level. (📖 p. 193)



15.6 Changing the coolant ↩



Warning

Danger of scalding During motorcycle operation, the coolant gets very hot and is under pressure.

- Do not open the radiator, the radiator hoses or other cooling system components if the engine or the cooling system are at operating temperature.
- Allow the cooling system and the engine to cool down before you open the radiator, the radiator hoses or other components of the cooling system.
- In the event of scalding, rinse the area affected immediately with lukewarm water.



Warning

Danger of poisoning Coolant is toxic and a health hazard.

- Keep coolant out of the reach of children.
- Do not allow coolant to come into contact with the skin, the eyes and clothing.
- Consult a doctor immediately if coolant is swallowed.
- Rinse the affected area immediately with plenty of water in the event of contact with the skin.
- Rinse eyes thoroughly with water and consult a doctor immediately if coolant gets into the eyes.
- Change clothing if coolant spills onto your clothing.

Preparatory work

- Remove the engine guard. (📖 p. 120)

15 COOLING SYSTEM

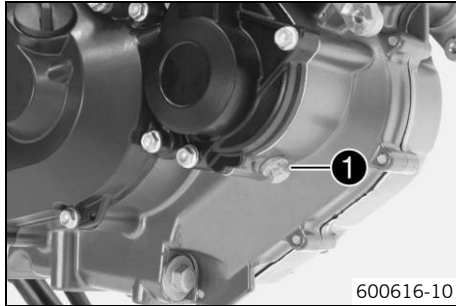

Main work

- Position the motorcycle upright.
- Place a suitable container under the engine.
- Remove screw **1**.

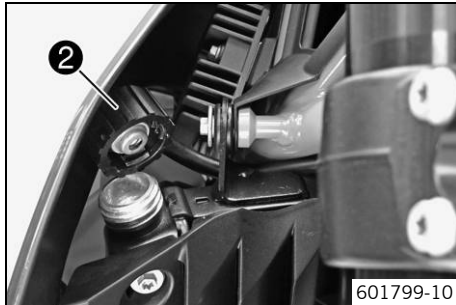

- Remove radiator cap **2**.
- Completely drain the coolant.

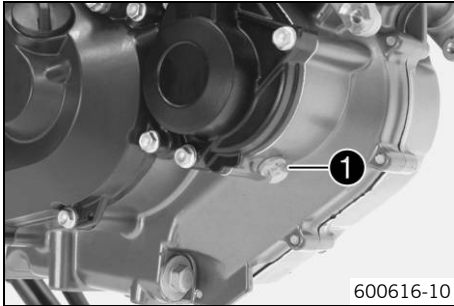

- Mount and tighten screw **1** with a new seal ring.

Guideline

Plug, drain hole of water pump	M10x1	15 Nm (11.1 lbf ft)
--------------------------------	-------	---------------------



- Stand the motorcycle on its side stand on a horizontal surface.
- Refill with coolant.

Coolant	1.20 l (1.27 qt.)	Coolant (📖 p. 257)
---------	----------------------	--------------------

- Completely fill the radiator with coolant.
- Mount radiator cap **2**.

15 COOLING SYSTEM

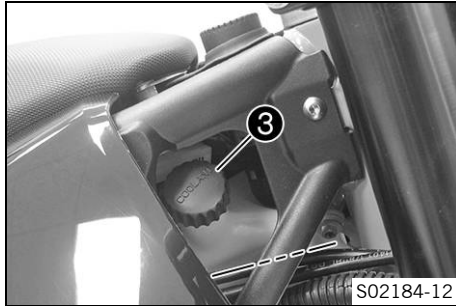

- Remove cover ③ of the compensating tank.
- Add coolant to the level shown in the figure.
- Mount cover ③ of the compensating tank.



Danger

Danger of poisoning Exhaust gases are toxic and inhaling them may result in unconsciousness and death.

- Always make sure there is sufficient ventilation when running the engine.
- Use an effective exhaust extraction system when starting or running the engine in an enclosed space.

- Start the engine and run it until the 5th bar of the temperature indicator lights up.
- Stop the engine and allow it to cool down.
- Check the coolant level. (📖 p. 193)

Finishing work

- Install the engine guard. (📖 p. 121)

16.1 Adjusting the engine characteristic

Preparatory work

- Switch off the ignition by turning the ignition key to position **OFF** ☒.
- Remove the seat. (📖 p. 102)

Main work

- Pull the **Map-Select** switch and holder ❶ upward off of the retaining bracket.
- Pull the **Map-Select** switch out of the holder.

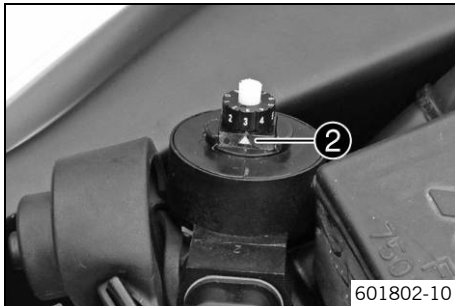
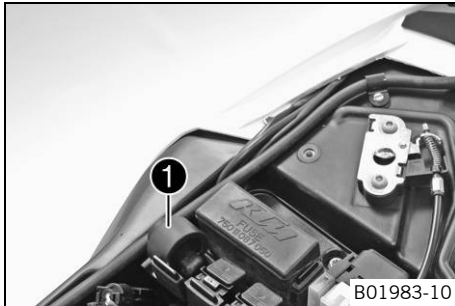

- Turn the adjusting wheel until the desired digit is next to marking ❷.

Set the Map-Select switch to Soft.

- Set the adjusting wheel to position **1**.
✓ Soft – reduced homologated peak performance for better driveability.

Set the Map-Select switch to Advanced.

- Set the adjusting wheel to position **2**.

- ✓ Advanced – homologated performance with extremely direct responsiveness.

Set the Map-Select switch to Standard.

- Set the adjusting wheel to position **3, 4, 5, 6, 7, 8** or **9**.
- ✓ Standard – homologated performance with balanced responsiveness.

Set the Map-Select switch to poor fuel quality.

- Set the adjusting wheel to position **0**.
- ✓ Poor fuel quality – homologated performance is reduced in accordance with the fuel quality, use for no more than 1 tank of fuel
- Position the **Map-Select** switch in the holder.
- Slide the **Map-Select** switch with the holder downward onto the retaining bracket.

Finishing work

- Mount the seat. (📖 p. 102)

16.2 Checking the basic position of the shift lever



Info

When driving, the shift lever must not touch the rider's boot when in the basic position. When the shift lever keeps touching the boot, the transmission will be subject to an excessive load.

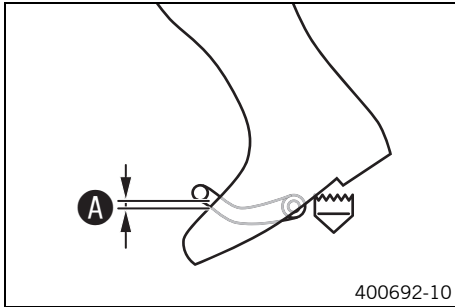

- Sit on the vehicle in the riding position and determine distance **A** between the upper edge of your boot and the shift lever.

Distance between shift lever and upper edge of boot	10 ... 20 mm (0.39 ... 0.79 in)
---	---------------------------------

- » If the distance does not meet specifications:
 - Adjust the basic position of the shift lever. 🛠️ (📖 p. 205)

16.3 Adjusting the basic position of the shift lever 🛠️

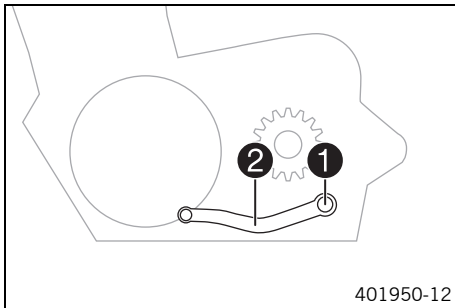

- Remove screw **1** with the washers and take off shift lever **2**.

16 TUNING THE ENGINE

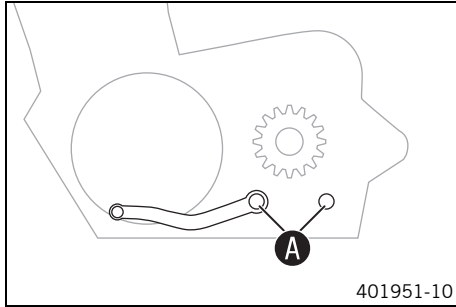

- Clean gear teeth **A** of the shift lever and shift shaft.
- Mount shift lever **2** on the shift shaft in the required position and engage the gearing.

i Info

The range of adjustment is limited.
The shift lever must not come into contact with any other vehicle components during the shift procedure.

- Mount and tighten screw **1** with washers.

Guideline

Screw, shift lever	M6	14 Nm (10.3 lbf ft) Loctite®243™
--------------------	----	--

17.1 Checking the engine oil level



Info

The engine oil level must be checked when the engine is warm.

Condition

The engine is at operating temperature.

Preparatory work

- Stand the motorcycle upright on a horizontal surface.

Main work

- Check the engine oil level.

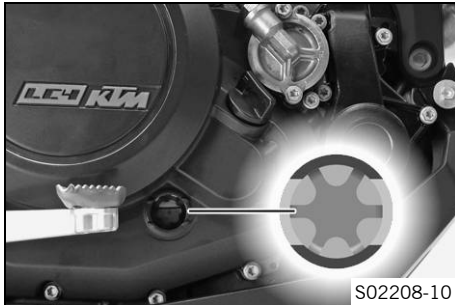

Info

After switching off the engine, wait one minute before checking the level.

The engine oil must be between the lower and upper edge of the oil level viewer.

- » If the engine oil level is not at the specified level:
 - Add engine oil. (📖 p. 216)

17.2 Changing the engine oil and filter, cleaning the oil screens 🛠️



- Drain the engine oil. 🛠️ (📖 p. 208)
- Remove the oil filter. 🛠️ (📖 p. 210)
- Clean the oil screens. 🛠️ (📖 p. 211)
- Install the oil filter. 🛠️ (📖 p. 214)
- Fill up with engine oil. 🛠️ (📖 p. 214)

17.3 Draining the engine oil 🛠️



Warning

Danger of scalding Engine and gear oil get very hot when the motorcycle is ridden.

- Wear suitable protective clothing and safety gloves.
- In the event of scalding, rinse the area affected immediately with lukewarm water.



Warning

Environmental hazard Hazardous substances cause environmental damage.

- Dispose of oils, grease, filters, fuel, cleaning agents, brake fluid, etc., correctly and in compliance with the applicable regulations.



Info

Drain the engine oil while the engine is at operating temperature.

Preparatory work

- Remove the engine guard. (📖 p. 120)

Main work

- Place a suitable container under the engine.
- Remove oil drain plug **1** with the magnet and seal ring.
- Completely drain the engine oil.

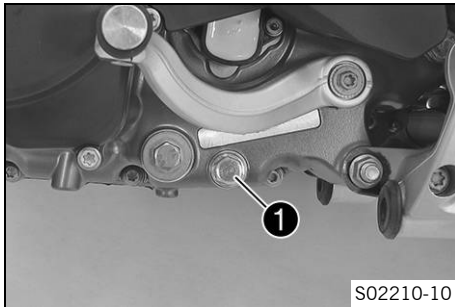

S02210-10

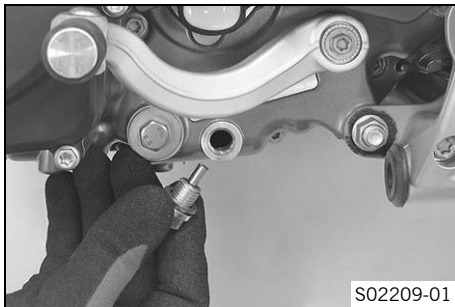

S02209-01

- Thoroughly clean the oil drain plug with magnet.
- Mount the oil drain plug with the magnet and seal ring and tighten it.

Guideline

Oil drain plug with magnet	M12x1.5	20 Nm (14.8 lbf ft)
----------------------------	---------	---------------------

17.4 Removing the oil filter ↴



Warning

Danger of scalding Engine and gear oil get very hot when the motorcycle is ridden.

- Wear suitable protective clothing and safety gloves.
- In the event of scalding, rinse the area affected immediately with lukewarm water.



Warning

Environmental hazard Hazardous substances cause environmental damage.

- Dispose of oils, grease, filters, fuel, cleaning agents, brake fluid, etc., correctly and in compliance with the applicable regulations.

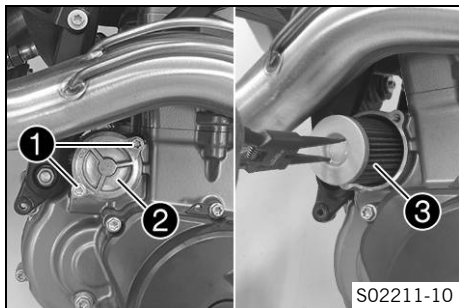

Preparatory work

- Place a suitable container under the engine.

Main work

- Remove screws ❶. Remove the oil filter cover ❷ with the O-ring.
- Pull oil filter ❸ out of the oil filter housing.

Lock ring plier (51012011000)

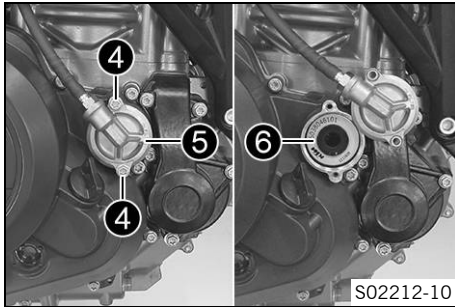

- Remove screws **4**. Remove the oil filter cover **5** with the O-ring.
- Pull oil filter **6** out of the oil filter housing.

Lock ring plier (51012011000)

- Completely drain the engine oil.
- Thoroughly clean the parts and sealing area.

17.5 Cleaning the oil screens



Warning

Danger of scalding Engine and gear oil get very hot when the motorcycle is ridden.

- Wear suitable protective clothing and safety gloves.
- In the event of scalding, rinse the area affected immediately with lukewarm water.



Warning

Environmental hazard Hazardous substances cause environmental damage.

- Dispose of oils, grease, filters, fuel, cleaning agents, brake fluid, etc., correctly and in compliance with the applicable regulations.

Preparatory work

- Place a suitable container under the engine.

17 SERVICE WORK ON THE ENGINE

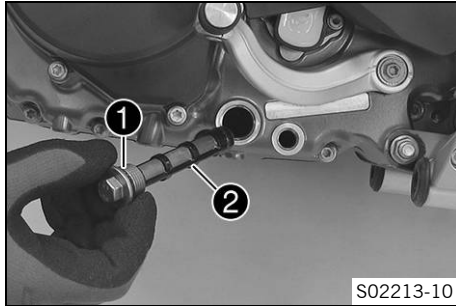

Main work

- Remove screw plug ① with oil screen ② and the O-rings.

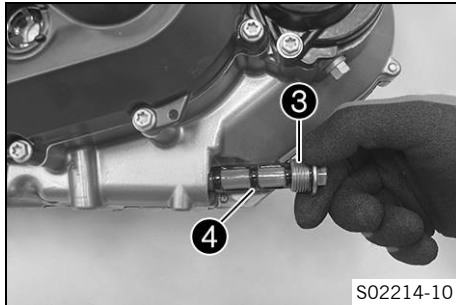

- Remove screw plug ③ with oil screen ④ and the O-rings.
- Completely drain the engine oil.
- Thoroughly clean the parts and sealing surface.

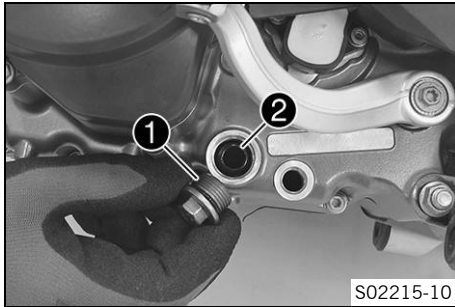

- Position oil screen **2** with the O-rings.
- Mount and tighten screw plug **1** with the O-ring.

Guideline

Plug, oil screen	M20x1.5	15 Nm (11.1 lbf ft)
------------------	---------	---------------------

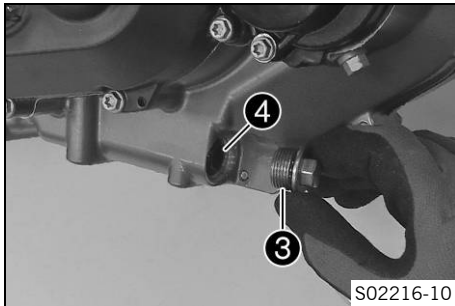

- Position oil screen **4** with the O-rings.
- Mount and tighten screw plug **3** with the O-ring.

Guideline

Plug, oil screen	M20x1.5	15 Nm (11.1 lbf ft)
------------------	---------	---------------------

17 SERVICE WORK ON THE ENGINE

17.6 Installing the oil filter ↗

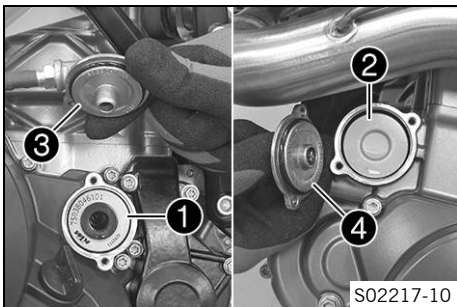

- Insert oil filters ① and ②.
- Oil the O-rings of the oil filter covers. Mount oil filter covers ③ and ④.
- Mount and tighten the screws.

Guideline

Screw, oil filter cover	M5	6 Nm (4.4 lbf ft)
-------------------------	----	-------------------

17.7 Filling up with engine oil ↗



Info

Too little engine oil or poor-quality engine oil results in premature wear to the engine.

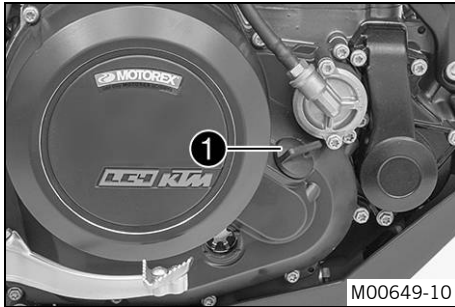

Main work

- Remove filler plug with O-ring ❶ from the clutch cover and add engine oil.

Engine oil	1.70 l (1.8 qt.)	Engine oil (SAE 10W/60) (00062010035) (📖 p. 258)
Engine oil Alternative engine oil		Engine oil (SAE 10W/50) (📖 p. 259)

- Refit plug with O-ring ❶ and tighten it.



Danger

Danger of poisoning Exhaust gases are toxic and inhaling them may result in unconsciousness and death.

- Always make sure there is sufficient ventilation when running the engine.
- Use an effective exhaust extraction system when starting or running the engine in an enclosed space.

- Start the engine and check that it is oil-tight.

Finishing work

- Install the engine guard. (📖 p. 121)

- Check the engine oil level. (📖 p. 207)

17.8 Adding engine oil



Info

Too little engine oil or poor-quality engine oil results in premature wear of the engine.

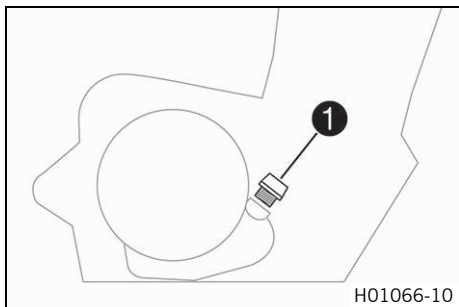

Main work

- Remove filler plug **1** and the O-ring from the clutch cover, and fill up with engine oil.

Engine oil (SAE 10W/60) (00062010035) (📖 p. 258)
--

Engine oil (SAE 10W/50) (📖 p. 259)



Info

In order to achieve optimal engine performance, it is not advisable to mix different engine oils. We recommended changing the engine oil when necessary.

- Mount and tighten oil filler plug **1** with the O-ring.



Danger

Danger of poisoning Exhaust gases are toxic and inhaling them may result in unconsciousness and death.

- Always make sure there is sufficient ventilation when running the engine.
- Use an effective exhaust extraction system when starting or running the engine in an enclosed space.

- Start the engine and check that it is oil-tight.

Finishing work

- Check the engine oil level. (📖 p. 207)



18.1 Cleaning the motorcycle

Note

Material damage Components become damaged or destroyed if a pressure cleaner is used incorrectly. The high pressure forces water into the electrical components, connectors, throttle cables, and bearings, etc. Pressure which is too high causes malfunctions and destroys components.

- Do not direct the water jet directly on to electrical components, connectors, throttle cables or bearings.
- Maintain a minimum distance between the nozzle of the pressure cleaner and the component.

Minimum clearance

60 cm (23.6 in)



Warning

Environmental hazard Hazardous substances cause environmental damage.

- Dispose of oils, grease, filters, fuel, cleaning agents, brake fluid, etc., correctly and in compliance with the applicable regulations.
-



Info

If you clean the motorcycle regularly, its value and appearance will be maintained over a long period. Avoid direct sunshine on the motorcycle during cleaning.

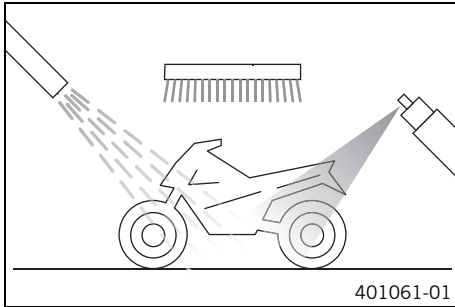

- Seal the exhaust system to keep water out.
- First remove coarse dirt particles with a gentle spray of water.
- Spray very dirty areas with a normal motorcycle cleaner and then clean with a brush.

Motorcycle cleaner (📖 p. 261)



Info

Use warm water containing normal motorcycle cleaner and a soft sponge.

Never apply motorcycle cleaner to the dry vehicle; always rinse with water first.

If the vehicle was operated in road salt, clean it with cold water. Warm water enhances the corrosive effects of salt.

- After rinsing the motorcycle with a gentle spray of water, allow it to dry thoroughly.
- Remove the plug from the exhaust system.



Warning

Danger of accidents Moisture and dirt impair the brake system.

- Brake carefully several times to dry out and remove dirt from the brake linings and the brake discs.

- After cleaning, ride a short distance until the engine reaches operating temperature.

**Info**

The heat produced causes water at inaccessible locations in the engine and brake system to evaporate.

- Push back the protection covers of the handlebar controls to allow any water that has penetrated to evaporate.
- After the motorcycle has cooled off, lubricate all moving parts and bearings.
- Clean the chain. (📖 p. 106)
- Treat bare metal parts (except for brake discs and exhaust system) with anti-corrosion materials.

Preserving materials for paints, metal and rubber
(📖 p. 262)

- Treat all painted parts with a mild paint polish.

Perfect Finish and high gloss polish for paints (📖 p. 262)

**Info**

Do not polish parts that were matte when delivered as this would strongly impair the material quality.

- Treat all plastic parts and powder-coated parts with a mild cleaning and care agent.

Special cleaner for glossy and matte paint finishes, metal and plastic surfaces (📖 p. 262)

- Lubricate the ignition/steering lock.

Universal oil spray (📖 p. 262)



18.2 Checks and maintenance steps for winter operation



Info

If you use the motorcycle in winter, you must expect salt on the roads. You should therefore take precautions against aggressive road salt.

If the vehicle was operated in road salt, clean it with cold water after riding. Warm water would enhance the corrosive effects of salt.

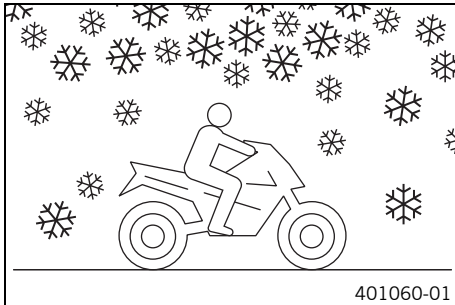

- Clean the motorcycle. (📖 p. 218)
- Clean the brake system.



Info

After **EVERY** trip on salted roads, thoroughly wash the brake calipers and brake linings with cold water and dry carefully. This should be done after the parts are cooled down and while they are installed.

After use on salted roads, clean the motorcycle thoroughly with cold water and dry it properly.

- Treat the engine, the swingarm, and all other bare or galvanized parts (except brake discs) with a wax-based anti-corrosion substance.

**Info**

To prevent serious reduction of the braking efficiency, make sure no anti-corrosion substance gets on to the brake discs.

-
- Clean the chain. (📖 p. 106)



19.1 Storage

**Info**

If you want to garage the motorcycle for a longer period, take the following actions. Before storing the motorcycle, check all parts for function and wear. If service, repairs, or replacements are necessary, you should do this during the storage period (less workshop overload). In this way, you can avoid long workshop waiting times at the start of the new season.

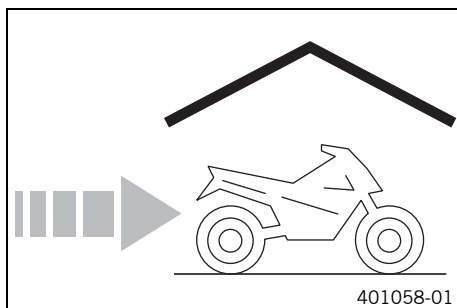

- When refueling for the last time before taking the motorcycle out of service, add fuel additive.

Fuel additive (📖 p. 261)

- Refuel. (📖 p. 71)
- Clean the motorcycle. (📖 p. 218)
- Change the engine oil and filter, clean the oil screens. 🛠️ (📖 p. 208)
- Check the antifreeze and coolant level. (📖 p. 190)
- Check the tire air pressure. (📖 p. 160)
- Remove the battery. 🛠️ (📖 p. 164)
- Recharge the battery. 🛠️ (📖 p. 169)

Guideline

Storage temperature of battery without direct sunshine	0 ... 35 °C (32 ... 95 °F)
--	----------------------------

- Store the vehicle in a dry location that is not subject to large fluctuations in temperature.

**Info**

KTM recommends jacking up the motorcycle.

-
- Raise the motorcycle with a lift stand. (📖 p. 95)
 - Cover the motorcycle with a tarp or similar cover that is permeable to air.

**Info**

Do not use non-porous materials since they prevent humidity from escaping, thus causing corrosion. Avoid running the engine for a short time only. Since the engine cannot warm up properly, the water vapor produced during combustion condenses and causes valves and exhaust system to rust.



19.2 Preparing for use after storage

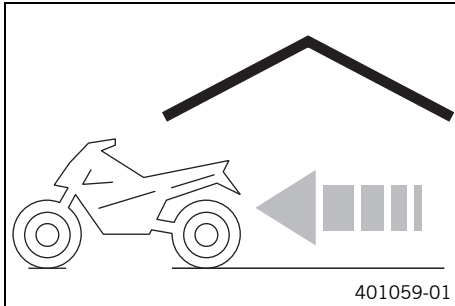

- Remove the motorcycle from the lift stand. (📖 p. 95)
- Recharge the battery. 🛡️ (📖 p. 169)
- Install the battery. 🛡️ (📖 p. 167)
- Set the clock. (📖 p. 38)
- Perform checks and maintenance measures when preparing for use. (📖 p. 56)
- Take a test ride.

20 TROUBLESHOOTING





Faults	Possible cause	Action
The engine does not turn when the starter button is pressed	Operating error	– Carry out the start procedure. (📖 p. 57)
	The battery is discharged	– Recharge the battery. 🛠️ (📖 p. 169) – Check the quiescent current. 🛠️
	Fuses 1, 2, 3 are blown	– Change the fuses of individual power consumers. (📖 p. 176)
	Main fuse burned out	– Change the main fuse. (📖 p. 172)
	No ground connection present	– Check the ground connection.
Engine turns only if the clutch lever is drawn	The vehicle is in gear	– Shift gear to neutral.
	The vehicle is in gear and the side stand is folded out	– Shift gear to neutral.
Engine turns but does not start.	Operating error	– Carry out the start procedure. (📖 p. 57)
	Fuse 3 blown	– Change the fuses of individual power consumers. (📖 p. 176)
	The plug-in connection of the fuel hose connection is not connected	– Connect the plug-in connection of the fuel line.
	Defect in fuel injection system	– Read out the fault memory using the KTM diagnostics tool. 🛠️





Faults	Possible cause	Action
Engine turns but does not start.	Throttle opened while starting	<ul style="list-style-type: none"> – When starting, DO NOT open the throttle – Carry out the start procedure. (📖 p. 57)
Engine has too little power.	Air filter is very dirty	<ul style="list-style-type: none"> – Remove the air filter. 🛠️ (📖 p. 103) – Install the air filter. 🛠️ (📖 p. 104)
	Fuel screen is very dirty	– Change fuel screen. 🛠️
	Fuel filter is very dirty	– Check the fuel pressure. 🛠️
	Defect in fuel injection system	– Read out the fault memory using the KTM diagnostics tool. 🛠️
	Map-Select switch incorrectly adjusted	– Adjust the engine characteristic. (📖 p. 203)
Engine overheats.	Too little coolant in cooling system	<ul style="list-style-type: none"> – Check the cooling system for leakage. – Check the coolant level. (📖 p. 193)
	Radiator fins very dirty	– Clean radiator fins.
	Foam formation in cooling system	<ul style="list-style-type: none"> – Drain the coolant. 🛠️ (📖 p. 195) – Fill/bleed the cooling system. 🛠️ (📖 p. 197)
	Buckled or damaged radiator hose	– Change the radiator hose. 🛠️
	Thermostat is faulty	– Check the thermostat. 🛠️

Faults	Possible cause	Action
Engine overheats.	Fuse 4 blown	– Change the fuses of individual power consumers. (📖 p. 176)
	Defect in radiator fan system	– Check the radiator fan system. 🛠️
	Air in cooling system	– Fill/bleed the cooling system. 🛠️ (📖 p. 197)
FI warning lamp (MIL) lights up/flashes	Defect in fuel injection system	– Read out the fault memory using the KTM diagnostics tool. 🛠️
N The idling speed indicator lamp does not light up when the transmission is in neutral	Gear position sensor not programmed	– Read out the fault memory using the KTM diagnostics tool. 🛠️
Engine dies during the journey	Lack of fuel	– Refuel. (📖 p. 71)
	Fuse 1, 2 or 3 blown	– Change the fuses of individual power consumers. (📖 p. 176)
ABS warning lamp lights up	The ABS fuse is blown	– Change the ABS fuses. (📖 p. 174)
	Large difference in wheel speeds of the front and rear wheels	– Stop the vehicle, switch off the ignition, and start it again.
	Malfunction in ABS	– Read out the ABS fault memory using the KTM diagnostics tool. 🛠️
High oil consumption	Engine vent hose bent	– Route the vent hose without bends or change it if necessary.
	Engine oil level too high	– Check the engine oil level. (📖 p. 207)





Faults	Possible cause	Action
High oil consumption	Engine oil too thin (low viscosity)	– Change the engine oil and filter, clean the oil screens. 🛠️ (📖 p. 208)
Headlight and parking light are not functioning	Fuse 6 blown	– Change the fuses of individual power consumers. (📖 p. 176)
Turn signal, brake light and horn not functioning	Fuse 5 blown	– Change the fuses of individual power consumers. (📖 p. 176)
Time is not (correctly) displayed	Fuse 1 blown	– Change the fuses of individual power consumers. (📖 p. 176) – Set the clock. (📖 p. 38)
Battery discharged	Ignition not switched off when vehicle was parked	– Recharge the battery. 🛠️ (📖 p. 169)
	Battery is not charged by alternator	– Check the charging voltage. 🛠️ – Check the quiescent current. 🛠️
Combination instrument shows nothing in the display	Fuse 1 or 2 blown	– Change the fuses of individual power consumers. (📖 p. 176) – Set the clock. (📖 p. 38)





21 BLINK CODE

Blink code for malfunction indicator lamp	 02 Malfunction indicator lamp flashes 2x short
Error level condition	Crankshaft position sensor - circuit fault
Blink code for malfunction indicator lamp	 09 Malfunction indicator lamp flashes 9x short
Error level condition	Manifold absolute pressure sensor cylinder 1 - input signal too low
	Manifold absolute pressure sensor cylinder 1 - input signal too high
Blink code for malfunction indicator lamp	 12 Malfunction indicator lamp flashes 1x long, 2x short
Error level condition	Engine coolant temperature sensor - input signal too low
	Engine coolant temperature sensor - input signal too high
Blink code for malfunction indicator lamp	 13 Malfunction indicator lamp flashes 1x long, 3x short
Error level condition	Intake air temperature sensor - input signal too low
	Intake air temperature sensor - input signal too high





Blink code for malfunction indicator lamp	 14 Malfunction indicator lamp flashes 1x long, 4x short
Error level condition	Ambient air pressure sensor - input signal too low Ambient air pressure sensor - input signal too high
Blink code for malfunction indicator lamp	 15 Malfunction indicator lamp flashes 1x long, 5x short
Error level condition	Rollover sensor - input signal too low Rollover sensor - input signal too high
Blink code for malfunction indicator lamp	 17 Malfunction indicator lamp flashes 1x long, 7x short
Error level condition	Lambda sensor cylinder 1, sensor 1 - circuit fault
Blink code for malfunction indicator lamp	 22 Malfunction indicator lamp flashes 2x long, 2x short
Error level condition	Gear position sensor - circuit fault





21 BLINK CODE

Blink code for malfunction indicator lamp	 24 Malfunction indicator lamp flashes 2x long, 4x short
Error level condition	System voltage - circuit fault
Blink code for malfunction indicator lamp	 25 Malfunction indicator lamp flashes 2x long, 5x short
Error level condition	Side stand switch - circuit fault
Blink code for malfunction indicator lamp	 27 Malfunction indicator lamp flashes 2x long, 7x short
Error level condition	Accelerator position sensor circuit fault - accelerator position sensor voltage
Blink code for malfunction indicator lamp	 33 Malfunction indicator lamp flashes 3x long, 3x short
Error level condition	Injector cylinder 1 - circuit fault
Blink code for malfunction indicator lamp	 37 Malfunction indicator lamp flashes 3x long, 7x short
Error level condition	Ignition coil 1, cylinder 1 - circuit fault





Blink code for malfunction indicator lamp	 39 Malfunction indicator lamp flashes 3x long, 9x short
Error level condition	Ignition coil 2, cylinder 1 - circuit fault
Blink code for malfunction indicator lamp	 41 Malfunction indicator lamp flashes 4x long, 1x short
Error level condition	Fuel pump controller - short circuit to ground or open circuit
	Fuel pump controller - input signal too high
Blink code for malfunction indicator lamp	 45 Malfunction indicator lamp flashes 4x long, 5x short
Error level condition	Lambda sensor heater cylinder 1, sensor 1 - short circuit to ground or open circuit
	Lambda sensor heater cylinder 1, sensor 1 - input signal too high
Blink code for malfunction indicator lamp	 65 Malfunction indicator lamp flashes 6x long, 5x short
Error level condition	E²PROM Error

21 BLINK CODE

Blink code for malfunction indicator lamp	 82 Malfunction indicator lamp flashes 8x long, 2x short
Error level condition	Throttle position sensor circuit A - input signal too high
	Throttle position sensor circuit A - input signal too low
Blink code for malfunction indicator lamp	 83 Malfunction indicator lamp flashes 8x long, 3x short
Error level condition	Accelerator position sensor - input signal too low
	Accelerator position sensor - input signal too high
Blink code for malfunction indicator lamp	 84 Malfunction indicator lamp flashes 8x long, 4x short
Error level condition	Throttle position sensor circuit A and B - plausibility fault
Blink code for malfunction indicator lamp	 85 Malfunction indicator lamp flashes 8x long, 5x short
Error level condition	Accelerator position sensor circuit A - input signal too low
	Accelerator position sensor circuit A - input signal too high

Blink code for malfunction indicator lamp	 86 Malfunction indicator lamp flashes 8x long, 6x short
Error level condition	Accelerator position sensor circuit B - input signal too high
Blink code for malfunction indicator lamp	 87 Malfunction indicator lamp flashes 8x long, 7x short
Error level condition	Accelerator position sensor circuit A and B - plausibility fault
Blink code for malfunction indicator lamp	 90 Malfunction indicator lamp flashes 9x long
Error level condition	Throttle position - circuit fault
	DBW internal power relay - inactive
	DBW internal power relay - active
Blink code for malfunction indicator lamp	 89 Malfunction indicator lamp flashes 8x long, 9x short
Error level condition	DBW return spring - stuck open

21 BLINK CODE

Blink code for malfunction indicator lamp	 92 Malfunction indicator lamp flashes 9x long, 2x short
Error level condition	DBW throttle actuator control IC - stuck open
Blink code for malfunction indicator lamp	 93 Malfunction indicator lamp flashes 9x long, 3x short
Error level condition	CPU mutual - surveillance error
Blink code for malfunction indicator lamp	 94 Malfunction indicator lamp flashes 9x long, 4x short
Error level condition	DBW stop function system error - stop function A system error
Blink code for malfunction indicator lamp	 95 Malfunction indicator lamp flashes 9x long, 5x short
Error level condition	DBW stop function system error - stop function B system error
Blink code for malfunction indicator lamp	 96 Malfunction indicator lamp flashes 9x long, 6x short
Error level condition	System voltage - input voltage too low
	System voltage - input signal too high

22.1 Engine

Design	1-cylinder 4-stroke engine, water-cooled
Displacement	690 cm ³ (42.11 cu in)
Stroke	84.5 mm (3.327 in)
Bore	102 mm (4.02 in)
Compression ratio	12.6:1
Idle speed	
Coolant temperature: $\geq 70\text{ }^{\circ}\text{C}$ ($\geq 158\text{ }^{\circ}\text{F}$)	1,550 ... 1,650 rpm
Control	OHC, 4 valves controlled via rocker arm, chain drive
Valve diameter, intake	40 mm (1.57 in)
Valve diameter, exhaust	34 mm (1.34 in)
Valve play, cold	0.07 ... 0.13 mm (0.0028 ... 0.0051 in)
Crankshaft bearing	2 roller bearings
Conrod bearing	Needle bearing
Piston pin bearing	Piston pin with DLC coating
Pistons	Forged light alloy
Piston rings	1 L-ring, 1 tapered compression piston ring, 1 oil scraper ring
Engine lubrication	Semi-dry sump lubrication system with two rotor pumps
Primary transmission	36:79

22 TECHNICAL DATA

Clutch	APTC™ antihopping clutch in oil bath/hydraulically operated
Transmission	6-gear, claw shifted
Transmission ratio	
1st gear	14:35
2nd gear	16:28
3rd gear	21:28
4th gear	21:23
5th gear	23:22
6th gear	23:20
Mixture preparation	Electronic fuel injection
Ignition	Contactless controlled fully electronic ignition with digital ignition adjustment
Alternator	12 V, 224 W
Spark plug	
Inside spark plug	NGK LKAR8BI-9
Outside spark plug	NGK LMAR7A-9
Spark plug electrode gap	0.9 mm (0.035 in)
Cooling	Water cooling, permanent circulation of coolant by water pump
Starting aid	Electric starter, automatic decompressor

22.2 Engine tightening torques

Screw, membrane fixation	M3	2 Nm (1.5 lbf ft) Loctite®243™
Hose clamp, intake flange	M4	2.5 Nm (1.84 lbf ft)
Oil nozzle for conrod bearing lubrication	M4	2 Nm (1.5 lbf ft) Loctite®243™
Locking screw for bearing	M5	6 Nm (4.4 lbf ft) Loctite®243™
Remaining screws, engine	M5	6 Nm (4.4 lbf ft)
Screw, breather cover on valve cover	M5	6 Nm (4.4 lbf ft) Loctite®243™
Screw, clutch spring	M5	8 Nm (5.9 lbf ft)
Screw, cover plate for oil return line	M5	6 Nm (4.4 lbf ft)
Screw, gear sensor	M5	5 Nm (3.7 lbf ft) Loctite®243™
Screw, oil filter cover	M5	6 Nm (4.4 lbf ft)
Screw, oil pump cover, top	M5	6 Nm (4.4 lbf ft) Loctite®243™
Intake channel vacuum connection	M6	2.5 Nm (1.84 lbf ft) Loctite®243™
Remaining screws, engine	M6	10 Nm (7.4 lbf ft)

22 TECHNICAL DATA

Screw in alternator cover	M6	10 Nm (7.4 lbf ft)
Screw, alternator cover (chain shaft through-hole)	M6	10 Nm (7.4 lbf ft) Loctite®243™
Screw, autodecompression	M6	3 ... 4 Nm (2.2 ... 3 lbf ft) Loctite®243™
Screw, axial lock of camshaft	M6	10 Nm (7.4 lbf ft) Loctite®243™
Screw, clutch cover	M6	10 Nm (7.4 lbf ft)
Screw, clutch slave cylinder	M6x20	10 Nm (7.4 lbf ft) Loctite®243™
Screw, clutch slave cylinder	M6x35	10 Nm (7.4 lbf ft) Loctite®243™
Screw, cylinder	M6	10 Nm (7.4 lbf ft) Loctite®243™
Screw, cylinder head	M6	10 Nm (7.4 lbf ft) Loctite®243™
Screw, engine case	M6	10 Nm (7.4 lbf ft)
Screw, ignition coil	M6	10 Nm (7.4 lbf ft)
Screw, ignition pulse generator	M6	10 Nm (7.4 lbf ft) Loctite®243™
Screw, locking lever	M6	10 Nm (7.4 lbf ft) Loctite®243™
Screw, oil pump cover, bottom	M6	10 Nm (7.4 lbf ft) Loctite®243™

Screw, rocker arm shaft	M6	12 Nm (8.9 lbf ft)	
Screw, shift drum locating	M6	10 Nm (7.4 lbf ft)	Loctite®243™
Screw, shift lever	M6	14 Nm (10.3 lbf ft)	Loctite®243™
Screw, starter motor	M6	10 Nm (7.4 lbf ft)	Loctite®243™
Screw, stator	M6	10 Nm (7.4 lbf ft)	Loctite®243™
Screw, thermostat housing	M6	10 Nm (7.4 lbf ft)	Loctite®243™
Screw, timing chain guide rail	M6	10 Nm (7.4 lbf ft)	Loctite®2701™
Screw, timing chain tensioning rail	M6	10 Nm (7.4 lbf ft)	Loctite®2701™
Screw, valve cover	M6	10 Nm (7.4 lbf ft)	
Screw, water pump cover	M6	10 Nm (7.4 lbf ft)	
Screw, water pump wheel	M6	10 Nm (7.4 lbf ft)	Loctite®243™
Oil jet, piston cooling	M6x0.75	4 Nm (3 lbf ft)	Loctite®243™
Crankshaft clamp screw plug	M8	15 Nm (11.1 lbf ft)	
Nut, exhaust flange	M8	20 Nm (14.8 lbf ft)	Copper paste

22 TECHNICAL DATA

Stud, exhaust flange	M8	10 Nm (7.4 lbf ft) Loctite®243™
Cylinder head screw	M10	Tightening sequence: Tighten diagonally, beginning with the rear screw on the timing chain shaft. Step 1 15 Nm (11.1 lbf ft) Step 2 30 Nm (22.1 lbf ft) Step 3 45 Nm (33.2 lbf ft) Step 4 60 Nm (44.3 lbf ft) Lubricated with engine oil
Oil line for oil pressure sensor	M10x1	10 Nm (7.4 lbf ft)
Oil pressure sensor	M10x1	10 Nm (7.4 lbf ft)
Plug, drain hole of water pump	M10x1	15 Nm (11.1 lbf ft)
Screw plug, oil channel	M10x1	15 Nm (11.1 lbf ft) Loctite®243™
Screw plug, oil channel, for oil radiator	M10x1	15 Nm (11.1 lbf ft)
Screw, unlocking of timing chain tensioner	M10x1	10 Nm (7.4 lbf ft)
Spark plug outside	M10x1	11 Nm (8.1 lbf ft)

Spark plug inside	M12x1.25	18 Nm (13.3 lbf ft)
Coolant temperature sensor on cylinder head	M12x1.5	12 Nm (8.9 lbf ft)
Oil drain plug with magnet	M12x1.5	20 Nm (14.8 lbf ft)
Oil pressure regulator valve plug	M12x1.5	20 Nm (14.8 lbf ft)
Screw plug, oil channel	M14x1.5	15 Nm (11.1 lbf ft) Loctite®243™
Engine case stud	M16x1.5	25 Nm (18.4 lbf ft) Loctite®243™
Rotor nut	M18x1.5	100 Nm (73.8 lbf ft)
Nut, engine sprocket	M20x1.5	80 Nm (59 lbf ft) Loctite®243™
Nut, inner clutch hub	M20x1.5	100 Nm (73.8 lbf ft) Loctite®243™
Nut, primary gear	M20LHx1.5	90 Nm (66.4 lbf ft) Loctite®243™
Plug, oil screen	M20x1.5	15 Nm (11.1 lbf ft)
Plug, timing chain tensioner	M20x1.5	25 Nm (18.4 lbf ft)
Plug, oil thermostat	M24x1.5	15 Nm (11.1 lbf ft)
Screw in alternator cover	M24x1.5	8 Nm (5.9 lbf ft)

22.3 Capacities

22.3.1 Engine oil

Engine oil	1.70 l (1.8 qt.)	Engine oil (SAE 10W/60) (00062010035) (📖 p. 258)
Engine oil Alternative engine oil		Engine oil (SAE 10W/50) (📖 p. 259)

22.3.2 Coolant

Coolant	1.20 l (1.27 qt.)	Coolant (📖 p. 257)
---------	-------------------	--------------------

22.3.3 Fuel

Total fuel tank capacity, approx.	12 l (3.2 US gal)	Super unleaded (ROZ 95/RON 95/PON 91) (📖 p. 260)
-----------------------------------	-------------------	---

Fuel reserve, approx.	2.5 l (2.6 qt.)
-----------------------	-----------------

22.4 Chassis

Frame	Lattice frame made of chrome molybdenum steel tubing, powder-coated
Fork	WP Performance Systems 4860 MXTA SPLIT

Shock absorber	WP Performance Systems 4618 with Pro-Lever linkage
Suspension travel	
front	250 mm (9.84 in)
rear	250 mm (9.84 in)
Brake system	
front	Disc brake with dual-piston brake caliper, floating
rear	Disc brake with single-pot brake caliper, floating
Brake discs - diameter	
front	300 mm (11.81 in)
rear	240 mm (9.45 in)
Brake discs - wear limit	
front	4.5 mm (0.177 in)
rear	4.5 mm (0.177 in)
Tire air pressure, road, solo	
front	1.8 bar (26 psi)
rear	1.8 bar (26 psi)
Tire air pressure with passenger / fully loaded	
front	2.2 bar (32 psi)
rear	2.2 bar (32 psi)
Tire air pressure, offroad, single rider	
front	1.5 bar (22 psi)

22 TECHNICAL DATA

rear	1.5 bar (22 psi)
Secondary drive ratio	15:45
Chain	5/8 x 1/4" X-ring
Steering head angle	63°
Wheelbase	1,504 ± 15 mm (59.21 ± 0.59 in)
Seat height unloaded	910 mm (35.83 in)
Ground clearance unloaded	280 mm (11.02 in)
Weight without fuel, approx.	143 kg (315 lb.)
Maximum permissible front axle load	150 kg (331 lb.)
Maximum permissible rear axle load	200 kg (441 lb.)
Maximum permissible overall weight	350 kg (772 lb.)

22.5 Electrical system

Battery	YTZ10S	Battery voltage: 12 V Nominal capacity: 8.6 Ah maintenance-free
Fuse	58011109115	15 A
Fuse	58011109125	25 A
Fuse	58011109130	30 A
Fuse	75011088015	15 A
Fuse	75011088010	10 A

Headlight	H4 / socket P43t	12 V 60/55 W
Parking light	W5W / socket W2.1x9.5d	12 V 5 W
Instrument lights and indicator lamps	LED	
Turn signal	R10W / socket BA15s	12 V 10 W
Brake/tail light	LED	
License plate lamp	W5W / socket W2.1x9.5d	12 V 5 W

22.6 Tires

Front tire	Rear tire
90/90 - 21 M/C 54S TT Metzeler Enduro 3 Sahara	140/80 - 18 M/C 70S TT Metzeler Enduro 3 Sahara
The tires specified represent one of the possible series production tires. Additional information is available in the Service section under: http://www.ktm.com	

22.7 Fork

Fork part number	14.18.8N.10	
Fork	WP Performance Systems 4860 MXTA SPLIT	
Compression damping		
Comfort	20 clicks	
Standard	15 clicks	
Sport	10 clicks	
Full payload	10 clicks	
Rebound damping		
Comfort	20 clicks	
Standard	15 clicks	
Sport	10 clicks	
Full payload	10 clicks	
Spring length with preload spacer(s)	465 mm (18.31 in)	
Spring rate		
Medium (standard)	5.3 N/mm (30.3 lb/in)	
Air chamber length	120 \pm $\frac{10}{20}$ mm (4.72 \pm $\frac{0.39}{0.79}$ in)	
Fork length	895 mm (35.24 in)	
Fork oil per fork leg	635 ml (21.47 fl. oz.)	Fork oil (SAE 4) (48601166S1) ( p. 259)

22.8 Shock absorber

Shock absorber article number	15.18.7L.10
Shock absorber	WP Performance Systems 4618 with Pro-Lever linkage
Compression damping, high-speed	
Comfort	2 turns
Standard	1.5 turns
Sport	1 turn
Full payload	1 turn
Compression damping, low-speed	
Comfort	20 clicks
Standard	15 clicks
Sport	10 clicks
Full payload	10 clicks
Rebound damping	
Comfort	20 clicks
Standard	15 clicks
Sport	10 clicks
Full payload	10 clicks
Spring preload	20 mm (0.79 in)
Spring rate	
Medium (standard)	80 N/mm (457 lb/in)

Hard	85 N/mm (485 lb/in)
Spring length	220 mm (8.66 in)
Gas pressure	10 bar (145 psi)
Static sag	18 mm (0.71 in)
Riding sag	70 ... 80 mm (2.76 ... 3.15 in)
Fitted length	395 mm (15.55 in)
Shock absorber fluid (📖 p. 259)	SAE 2.5

22.9 Chassis tightening torques

Screw, chain guard	EJOT	2 Nm (1.5 lbf ft)
Screw, combination instrument	EJOT	1 Nm (0.7 lbf ft)
Screw, license plate holder, bottom	EJOT	3 Nm (2.2 lbf ft)
Screw, side cover on spoiler	EJOT	1 Nm (0.7 lbf ft)
Screw, side stand switch	EJOT	2 Nm (1.5 lbf ft)
Screw, SLS valve	EJOT	2 Nm (1.5 lbf ft)
Fitting, side stand switch	M4	2 Nm (1.5 lbf ft)
Spoke nipple, front wheel	M4.5	4 Nm (3 lbf ft)
Bolt, foot brake lever stub	M5	6 Nm (4.4 lbf ft)
Remaining nuts, chassis	M5	4 Nm (3 lbf ft)

Loctite®243™

Remaining screws, chassis	M5	4 Nm (3 lbf ft)
Screw, brake line holder on swingarm	M5	4 Nm (3 lbf ft)
Screw, cable on starter motor	M5	3 Nm (2.2 lbf ft)
Screw, combination switch, left	M5	3.5 Nm (2.58 lbf ft)
Screw, electrical holder	M5	3 Nm (2.2 lbf ft)
Screw, exhaust heat shield	M5	8 Nm (5.9 lbf ft)
		Loctite®243™
Screw, fuel hose clamp on fuel tank	M5	5 Nm (3.7 lbf ft)
Screw, fuel level sensor	M5	3 Nm (2.2 lbf ft)
Screw, fuel pump	M5	4 Nm (3 lbf ft)
Screw, fuel tank closure flange	M5	2.5 Nm (1.84 lbf ft)
Screw, headlight mask	M5	5 Nm (3.7 lbf ft)
Screw, pressure regulator	M5	4 Nm (3 lbf ft)
Screw, throttle grip	M5	3.5 Nm (2.58 lbf ft)
Spoke nipple, rear wheel	M5	4 Nm (3 lbf ft)
Remaining nuts, chassis	M6	10 Nm (7.4 lbf ft)
Remaining screws on fuel tank	M6	5 Nm (3.7 lbf ft)
Remaining screws, chassis	M6	10 Nm (7.4 lbf ft)
Screw connection, foot brake cylinder	M6	10 Nm (7.4 lbf ft)

22 TECHNICAL DATA

Screw, ABS control unit	M6	5 Nm (3.7 lbf ft)
Screw, ABS module retaining bracket on frame	M6	10 Nm (7.4 lbf ft)
Screw, air filter box top	M6	2 Nm (1.5 lbf ft)
Screw, ball joint of push rod on foot brake cylinder	M6	10 Nm (7.4 lbf ft) Loctite®243™
Screw, battery terminal	M6	4.5 Nm (3.32 lbf ft)
Screw, brake assembly	M6	5 Nm (3.7 lbf ft)
Screw, brake fluid reservoir of rear brake	M6	5 Nm (3.7 lbf ft)
Screw, chain guard	M6	2 Nm (1.5 lbf ft) Loctite®243™
Screw, chain guide	M6	8 Nm (5.9 lbf ft)
Screw, chain sliding guard	M6	8 Nm (5.9 lbf ft) Loctite®243™
Screw, clutch assembly	M6	5 Nm (3.7 lbf ft)
Screw, fan hood	M6	4 Nm (3 lbf ft)
Screw, front brake disc	M6	14 Nm (10.3 lbf ft) Loctite®243™
Screw, ignition lock	M6	10 Nm (7.4 lbf ft) Loctite®243™
Screw, lower radiator bracket	M6	8 Nm (5.9 lbf ft)

Screw, magnetic holder on side stand	M6	6 Nm (4.4 lbf ft) Loctite®243™
Screw, radiator bleeding	M6	8 Nm (5.9 lbf ft)
Screw, radiator guard	M6	8 Nm (5.9 lbf ft)
Screw, rear brake disc	M6	14 Nm (10.3 lbf ft) Loctite®243™
Screw, seat lock	M6	5 Nm (3.7 lbf ft)
Screw, side cover	M6	5 Nm (3.7 lbf ft)
Screw, upper radiator bracket	M6	10 Nm (7.4 lbf ft)
Screw, voltage regulator	M6	8 Nm (5.9 lbf ft)
Screw, wheel speed sensor	M6	6 Nm (4.4 lbf ft)
Nut, manifold on cylinder head	M8	20 Nm (14.8 lbf ft) Copper paste
Nut, rear sprocket screw	M8	35 Nm (25.8 lbf ft) Loctite®2701™
Remaining nuts, chassis	M8	25 Nm (18.4 lbf ft)
Remaining screws, chassis	M8	25 Nm (18.4 lbf ft)
Screw, bottom triple clamp	M8	12 Nm (8.9 lbf ft)
Screw, chain sliding piece	M8	15 Nm (11.1 lbf ft)
Screw, connection lever on frame	M8	30 Nm (22.1 lbf ft) Loctite®243™
Screw, foot brake lever	M8	25 Nm (18.4 lbf ft) Loctite®243™

22 TECHNICAL DATA

Screw, fork stub	M8	15 Nm (11.1 lbf ft)	
Screw, front brake caliper	M8	25 Nm (18.4 lbf ft)	Loctite®243™
Screw, front footrest bracket	M8	25 Nm (18.4 lbf ft)	Loctite®243™
Screw, fuel tank bracket	M8	15 Nm (11.1 lbf ft)	
Screw, fuel tank, bottom	M8	25 Nm (18.4 lbf ft)	Loctite®243™
Screw, fuel tank, top	M8	25 Nm (18.4 lbf ft)	Loctite®243™
Screw, grab handle	M8	10 Nm (7.4 lbf ft)	
Screw, handlebar clamp	M8	20 Nm (14.8 lbf ft)	
Screw, heel protector	M8x12	5 Nm (3.7 lbf ft)	Loctite®243™
Screw, license plate holder, top	M8	20 Nm (14.8 lbf ft)	
Screw, main silencer clamp	M8	12 Nm (8.9 lbf ft)	Copper paste
Screw, main silencer holder	M8	25 Nm (18.4 lbf ft)	
Screw, main silencer holder on fuel tank	M8	25 Nm (18.4 lbf ft)	
Screw, rear footrest bracket	M8x16	25 Nm (18.4 lbf ft)	
Screw, side stand bracket	M8	25 Nm (18.4 lbf ft)	Loctite®243™

Screw, spring holder on side stand bracket	M8	25 Nm (18.4 lbf ft) Loctite®243™
Screw, steering stem	M8	20 Nm (14.8 lbf ft)
Screw, top triple clamp	M8	17 Nm (12.5 lbf ft)
Engine carrying screw	M10	45 Nm (33.2 lbf ft) Loctite®243™
Remaining nuts, chassis	M10	45 Nm (33.2 lbf ft)
Remaining screws, chassis	M10	45 Nm (33.2 lbf ft)
Screw, bottom shock absorber	M10	45 Nm (33.2 lbf ft) Loctite®243™
Screw, engine bearer on frame	M10	45 Nm (33.2 lbf ft)
Screw, handlebar support	M10	40 Nm (29.5 lbf ft) Loctite®243™
Screw, side stand	M10	35 Nm (25.8 lbf ft) Loctite®243™
Screw, top shock absorber	M10	45 Nm (33.2 lbf ft) Loctite®243™
Banjo bolt, brake line	M10x1	25 Nm (18.4 lbf ft)
Screw, swingarm pivot	M12	80 Nm (59 lbf ft)
Lambda sensor	M12x1.25	25 Nm (18.4 lbf ft) Copper paste
Nut, linkage lever on swingarm	M14x1.5	100 Nm (73.8 lbf ft)
Nut, linkage lever to rocker arm	M14x1.5	100 Nm (73.8 lbf ft)

22 TECHNICAL DATA

Screw, radiator temperature sensor	M18	20 Nm (14.8 lbf ft)
Screw, bottom steering head	M20x1.5	60 Nm (44.3 lbf ft) Loctite®243™
Screw, top steering head	M20x1.5	12 Nm (8.9 lbf ft)
Screw, front wheel spindle	M24x1.5	45 Nm (33.2 lbf ft)
Nut, rear wheel spindle	M25x1.5	90 Nm (66.4 lbf ft)

Brake fluid DOT 4 / DOT 5.1

Standard/classification

- DOT

Guideline

- Use only brake fluid that complies with the specified standard (see specifications on the container) and that exhibits the corresponding properties.

Recommended supplier

Castrol

- REACT PERFORMANCE DOT 4

Motorex®

- Brake Fluid DOT 5.1

Coolant

Guideline

- Only use high-grade, silicate-free coolant with corrosion inhibitor additive for aluminum motors. Low grade and unsuitable antifreeze causes corrosion, deposits and frothing.
- Do not use pure water as only coolant is able to meet the requirements needed in terms of corrosion protection and lubrication properties.
- Only use coolant that complies with the requirements stated (see specifications on the container) and that has the relevant properties.

Antifreeze protection to at least	-25 °C (-13 °F)
-----------------------------------	-----------------

The mixture ratio must be adjusted to the necessary antifreeze protection. Use distilled water if the coolant needs to be diluted.

The use of premixed coolant is recommended.

Observe the coolant manufacturer specifications for antifreeze protection, dilution and miscibility (compatibility) with other coolants.

Recommended supplier

Motorex®

- **COOLANT M3.0**

Engine oil (SAE 10W/60) (00062010035)

Standard/classification

- JASO T903 MA (📖 p. 263)
- SAE (📖 p. 263) (SAE 10W/60)
- KTM LC4 2007+

Guideline

- Use only engine oils that comply with the specified standards (see specifications on the container) and that possess the corresponding properties.

Synthetic engine oil

Recommended supplier

Motorex®

- **Cross Power 4T**

Engine oil (SAE 10W/50)

Standard/classification

- JASO T903 MA (📖 p. 263)
- SAE (📖 p. 263) (SAE 10W/50)

Guideline

- Use only engine oils that comply with the specified standards (see specifications on the container) and that possess the corresponding properties.

Fully synthetic engine oil

Recommended supplier

Motorex®

- Power Synt 4T

Fork oil (SAE 4) (48601166S1)

Standard/classification

- SAE (📖 p. 263) (SAE 4)

Guideline

- Use only oils that comply with the specified standards (see specifications on the container) and that exhibit the corresponding properties.

Shock absorber fluid (SAE 2.5) (50180751S1)

Standard/classification

- SAE (📖 p. 263) (SAE 2.5)

Guideline

- Use only oils that comply with the specified standards (see specifications on the container) and that exhibit the corresponding properties.

Super unleaded (ROZ 95/RON 95/PON 91)

Standard/classification

- DIN EN 228 (ROZ 95/RON 95/PON 91)

Guideline

- Only use unleaded super fuel that matches or is equivalent to the specified fuel grade.
- Fuel with an ethanol content of up to 10 % (E10 fuel) is safe to use.



Info

Do **not** use fuel containing methanol (e. g. M15, M85, M100) or more than 10 % ethanol (e. g. E15, E25, E85, E100).

Chain cleaner

Recommended supplier

Motorex®

- Chain Clean

Fuel additive

Recommended supplier

Motorex®

- Fuel Stabilizer

Long-life grease

Recommended supplier

Motorex®

- Bike Grease 2000

Motorcycle cleaner

Recommended supplier

Motorex®

- Moto Clean

Off-road chain spray

Recommended supplier

Motorex®

- Chainlube Offroad

Perfect Finish and high gloss polish for paints

Recommended supplier

Motorex®

- Moto Polish & Shine

Preserving materials for paints, metal and rubber

Recommended supplier

Motorex®

- Moto Protect

Special cleaner for glossy and matte paint finishes, metal and plastic surfaces

Recommended supplier

Motorex®

- Quick Cleaner

Universal oil spray

Recommended supplier

Motorex®

- Joker 440 Synthetic

JASO T903 MA

Different technical development directions required a separate specification for motorcycles – the **JASO T903 MA** standard.

Earlier, engine oils from the automobile industry were used for motorcycles because there was no separate motorcycle specification.

Whereas long service intervals are demanded for automobile engines, the focus for motorcycle engines is on high performance at high engine speeds.

In most motorcycle engines, the transmission and clutch are lubricated with the same oil.

The **JASO MA** standard meets these special requirements.

SAE

The SAE viscosity classes were defined by the Society of Automotive Engineers and are used for classifying oils according to their viscosity. The viscosity describes only one property of oil and says nothing about quality.



26 INDEX OF SPECIAL TERMS

ABS	ABS	Safety system that prevents locking of the wheels when driving straight ahead without the influence of lateral forces
OBD	On-board diagnosis	Vehicle system, which monitors the specified parameters of the vehicle electronics

Art. no.	Article number
ca.	circa
cf.	compare
e.g.	for example
etc.	et cetera
i.a.	inter alia
no.	number
poss.	possibly



28.1 Red symbols

Red symbols indicate an error condition that requires immediate intervention.

	The coolant temperature warning lamp lights up red – The coolant temperature has reached a critical value.
	The oil pressure warning lamp lights up red – Engine oil pressure is too low. Stop immediately, taking care not to endanger yourself or other road users in the process, and switch off the engine.
	The battery warning lamp lights up red – The voltage in the vehicle system is too low.



28.2 Yellow and orange symbols

Yellow and orange symbols indicate an error condition that requires prompt intervention. Active driving aids are also represented by yellow or orange symbols.

	The fuel level warning lamp lights up yellow – The fuel level has reached the reserve mark. The display switches to TRIP F .
	Malfunction indicator lamp lights up/flashes yellow – The OBD has detected an error in the vehicle electronics. Come safely to a halt, and contact an authorized KTM workshop.
	ABS warning lamp lights up/flashes yellow – Status or error messages relating to ABS.

28.3 Green and blue symbols

Green and blue symbols reflect information.

	Turn signal indicator lamp flashes green – The turn signal is switched on.
	The idle indicator lamp lights up green – The transmission is in idle.
	The high beam indicator lamp lights up blue – The high beam is switched on.

A	
ABS	122
ABS fuses	
changing	174
Accessories	17
Air filter	
installing	104
removing	103
Antilock brake system	122
Applying the brakes	66
Auxiliary substances	17
B	
Battery	
installing	167
recharging	169
removing	164
Blink code	230-236
Brake discs	
checking	125
Brake fluid	
rear brake, adding	140
Topping up brake fluid of front brake	127
Brake fluid level	
checking the brake fluid level of front brake .	126
rear brake, checking	139
Brake linings	
front brake, changing	131
front brake, checking	130
rear brake, changing	143
rear brake, checking	142
Brakes	66
C	
Capacity	
coolant	244
engine oil	215, 244
fuel	72, 244
Chain	
checking	111
cleaning	106
dirt, checking for	105
Chain guide	
adjusting	116
checking	111
Chain tension	
adjusting	109

checking	107	Coolant	
Changing the headlight bulb	181	changing	199
Chassis number	24	checking the antifreeze and coolant level . . .	190
Checking the headlight setting	186	checking the level	193
Clutch		draining	195
fluid level, checking/correcting	118	Cooling system	189
Clutch lever	27	filling/bleeding	197
basic position, adjusting	117	Customer service	18
Combination instrument		D	
clock, setting	38	Diagnostics connector	188
coolant temperature indicator	42	Driving	60
display	35	E	
function buttons	33	Electric starter button	31
GEAr display	42	Emergency OFF switch	30
indicator lamps	34	Engine	
ODO display	39	running in	52
overview	32	Engine characteristic	
setting the kilometers or miles	37	adjusting	203
speed display	36	Engine guard	
tachometer	33	installing	121
time	38	removing	120
TRIP 1 display, setting/resetting	39	Engine number	25
TRIP 2 display, setting/resetting	40		
TRIP F display	41		

Engine oil	
adding	216
changing	208
draining	208
refilling	214
Engine oil level	
checking	207
Engine sprocket	
checking	111
Environment	15
F	
Figures	18
Filler cap	
closing	45
opening	43
Foot brake lever	48
basic position, adjusting	137
free travel, checking	136
Fork	78
compression damping, adjusting	78
dust boots, cleaning	96
rebound, adjusting	80
Fork part number	26
Fork protector	
positioning	98
remove	98
Front wheel	
installing	150
removing	148
Fuse	
individual power consumers, changing	176
H	
Hand brake lever	27
basic position, adjusting	124
Handlebar position	92
adjusting	93
Handrails	46
Headlight	
light range, adjusting	187
Headlight mask with headlight	
installing	180
removing	179
Horn button	28
I	
Ignition lock	31

Implied warranty	17
Intended use	11
K	
Key number	25
L	
Light switch	29
Loading the vehicle	53
Luggage	53
M	
Main fuse	
changing	172
Misuse	11
Motorcycle	
cleaning	218
lift stand, raising with	95
removing from lift stand	95
O	
Oil filter	
changing	208
installing	214
removing	210

Oil screens	
cleaning	208, 211
Operating substances	17
Owner's Manual	16
P	
Parking	68
Parking light bulb	
changing	183
Passenger footrest	46
Preparing for use	
advice on first use	50
after storage	225
checks and maintenance measures when	
preparing for use	56
Protective clothing	14
R	
Rear hub rubber dampers	
checking	156
Rear sprocket	
checking	111
Rear wheel	
installing	154

removing	152	rebound damping, adjusting	84
Refueling		riding sag, checking	88
fuel	71	spring preload, adjusting	89
Riding		static sag, checking	87
starting off	60	Shock absorber article number	26
Riding sag		Side stand	48
adjusting	91	Spare parts	17
S		Spoke tension	
Safe operation	13	checking	162
Seat		Starting	57
mounting	102	Steering head bearing play	
removing	102	adjusting	101
unlocking	45	checking	99
Service	18	Steering lock	31
Service schedule	74-77	Stopping	68
Shift lever	47	Storage	223
basic position, adjusting	205	T	
basic position, checking	204	Technical data	
Shifting	60	capacities	244
Shock absorber	78	chassis	244
compression damping, general	81	chassis tightening torques	250
high-speed compression damping, adjusting	83	electrical system	246
low-speed compression damping, adjusting	81	engine	237

engine tightening torques	239
fork	248
shock absorber	249
tires	247
Throttle grip	28
Tire air pressure	
checking	160
Tire condition	
checking	158
Transport	70
Troubleshooting	226-229
Turn signal bulb	
changing	184
Turn signal switch	29
Type label	24
U	
Use definition	11
V	
View of vehicle	
front left	20
rear right	22

W

Warranty	17
Winter operation	
checks and maintenance steps	221
Work rules	15

READY TO RACE

[» www.ktm.com](http://www.ktm.com)



3213745en

08/2017



KTM Sportmotorcycle GmbH
3230 Mattighofen/Austria
<http://www.ktm.com>



Photo: Mitterbauer/KTM